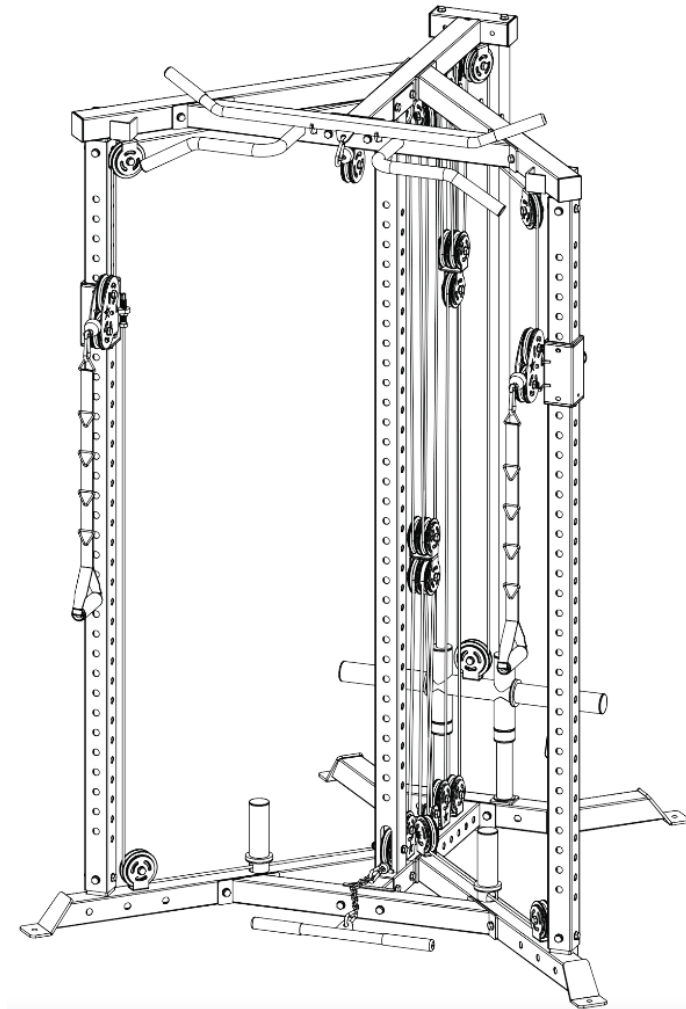



**PLATE LOADED  
ALL-IN-ONE TRAINER  
SKU: SS-FCT  
PO:**



## ASSEMBLY INSTRUCTIONS



**BELLSOFSTEEL**

**Stuck? Scan the QR code for the assembly video**

[www.bellsofsteel.com](http://www.bellsofsteel.com) | [www.bellsofsteel.us](http://www.bellsofsteel.us) | Telephone: 1-888-718-7997



# BUILDING STRENGTH, ONE BOLT AT A TIME.



## Welcome to Bells of Steel, you've made an excellent choice.

First off I want to say thank you for supporting my small business.

I've put significant thought into designing this product to enhance your lifting experience and help you reach your full potential. I hope you love it!

I've done my best to keep the setup of your new gear simple. If you find yourself needing a bit more assistance than the included instructions, check our youtube page for assembly videos or feel free to email us for troubleshooting guidance.

**Kaevon Khoozani**



Crush your Gains! Subscribe to our YouTube for workouts & how-to's.

**@BELLSOFSTEEL**



Warranty & returns? We got you covered—check here:

**[bellssofsteel.com/pages/warranty](https://bellssofsteel.com/pages/warranty)**

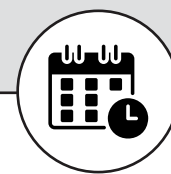

Changed your mind? No sweat. 30-day refund guarantee:

**[bellssofsteel.com/policies/refund-policy](https://bellssofsteel.com/policies/refund-policy)**



### Let us know how we've done

Love it? Leave a review! Hate it? We still read it. Help us get better by reviewing our products.



### Customer Notice

If you are missing any parts, or otherwise have any warranty issues/shipping damages, please file a warranty claim on our website.

Before discarding the box, please take clear photos of the box and shipping labels, as these may be required if parts are missing or the item is damaged.

# BEFORE WE BEGIN, LET'S STAY SAFE.



## A GUIDE TO SAFETY

---

We know you are excited to use your new Bells of Steel gear, but please read through this Guide to Safety to ensure you do not hurt yourself or others while exercising. It is your responsibility to ensure that all users of the equipment are informed of all warnings and instructions in this manual. TO REDUCE THE RISK OF SERIOUS INJURY, READ THE FOLLOWING IMPORTANT PRECAUTIONS BEFORE USING YOUR BELLS OF STEEL PRODUCT.





- ① Before starting any exercise program consult your physician. Be aware of your body's signals. Incorrect or excessive exercise can be damaging to your health. STOP EXERCISING IF YOU EXPERIENCE ANY OF THE FOLLOWING SYMPTOMS: PAIN, TIGHTNESS IN YOUR CHEST, IRREGULAR HEARTBEAT, SHORTNESS OF BREATH, LIGHTHEADEDNESS, DIZZINESS, OR FEELINGS OF NAUSEA. IF YOU EXPERIENCE ANY OF THESE SYMPTOMS, STOP EXERCISING IMMEDIATELY AND CONSULT YOUR PHYSICIAN BEFORE CONTINUING WITH YOUR EXERCISE PROGRAM.
- ② It is your responsibility to ensure there is enough space around the product for the intended exercise. Use the product on a flat surface and ensure at least 2 feet (60 cm) of free space around it.
- ③ Children and pets must not be let on or near the product. Moving parts and heavy features of the product can be dangerous and cause serious injury.
- ④ Read all instructions in this manual before using the product and use the product only as described in this manual.
- ⑤ It is your responsibility to ensure that all users of the product are adequately informed of all precautions, have read and understand all warnings, and are informed how to use the product properly.
- ⑥ Keep hands and feet from moving parts. Do not lean or rest on the product.
- ⑦ Wear athletic shoes for foot protection while exercising.
- ⑧ Your product is intended for use in cool, dry conditions. You should avoid storage in extreme cold, hot, or damp areas.
- ⑨ This product is designed for indoor use only.
- ⑩ Ensure that any weight pins that may be included with your product are completely inserted into an appropriate weight plate.
- ⑪ Ensure that any handles that may be included with your product are attached securely before using the product.
- ⑫ Ensure that any nuts and bolts that may be included with your product are securely tightened before use. Regularly re-tighten nuts and bolts.
- ⑬ Ensure any cables that may be included with your product always remain attached to their proper pulleys. If a cable bind occurs during exercise, stop immediately and inspect the part to ensure any interference is fixed.
- ⑭ Do not overexert yourself during any exercise program. Operate the product as intended.
- ⑮ The product should be anchored where required or whenever possible. The product should be secured when not in use.
- ⑯ The product is very heavy. Improper use or assembly can lead to serious injury or death.
- ⑰ SAVE AND REVIEW THESE INSTRUCTIONS.

NOW...



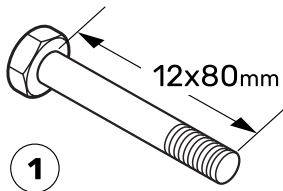
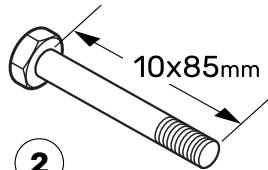
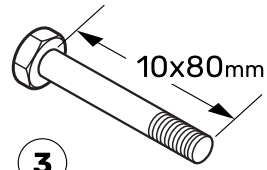
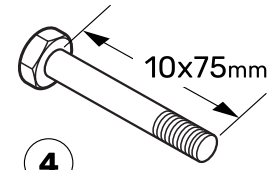
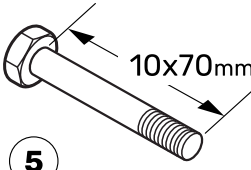
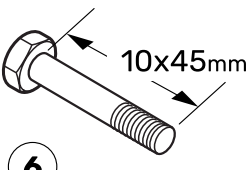
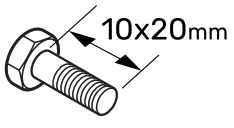
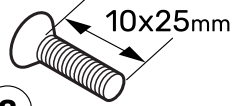



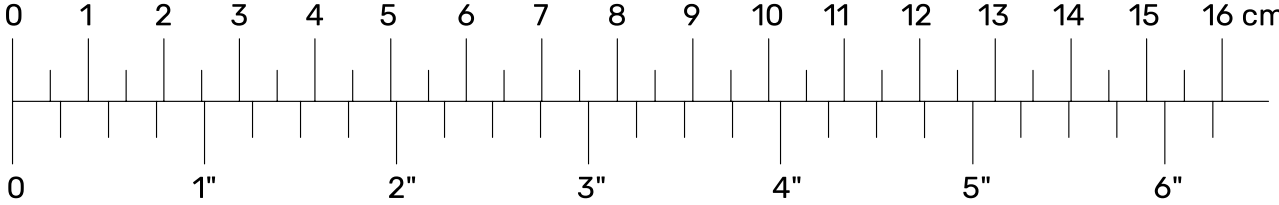

## LET THE GAINZ BEGIN

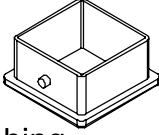
# PARTS LIST

## • Hardware Package

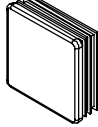
 <p><b>1</b> M12 x 80mm bolt x2</p>	 <p><b>2</b> M10 x 85mm bolt x2</p>	 <p><b>3</b> M10 x 80mm bolt x16</p>	 <p><b>4</b> M10 x 75mm bolt x6</p>	
 <p><b>5</b> M10 x 70mm bolt x8</p>	 <p><b>6</b> M10 x 45mm bolt x21</p>	 <p><b>7</b> M10 x 20mm bolt x10</p>	 <p><b>8</b> M10 x 25mm countersunk bolt x1</p>	
 <p><b>9</b> M12mm nut x2</p>	 <p><b>10</b> M10mm nut x47</p>	 <p><b>11</b> Ø 12mm washer x4</p>	 <p><b>12</b> Ø 10mm washer x110</p>	
				
<p>0 1 2 3 4 5 6 7 8 9 10 11 12 13 14 15 16 cm</p> <p>0 1" 2" 3" 4" 5" 6"</p>				

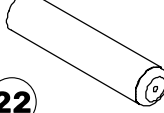
## • Preassembled

 <p><b>15</b> 60 x 75 Tube bushing x4</p>	 <p><b>16</b> M20-38 popper pin x2</p>	 <p><b>17</b> Ø 12-19-24 podwer bearing x4</p>	 <p><b>18</b> Ø 27-50 tube bushing x4</p>	
 <p><b>19</b> 60 tube plug x4</p>	 <p><b>20</b> 48 tube plug x4</p>	 <p><b>21</b> Ø 30 tube plug x4</p>	 <p><b>22</b> Ø 25-120 handle x4</p>	
 <p><b>23</b> Ø 48-65-8 buffer washer x4</p>				

# PARTS LIST

**24**  
x30

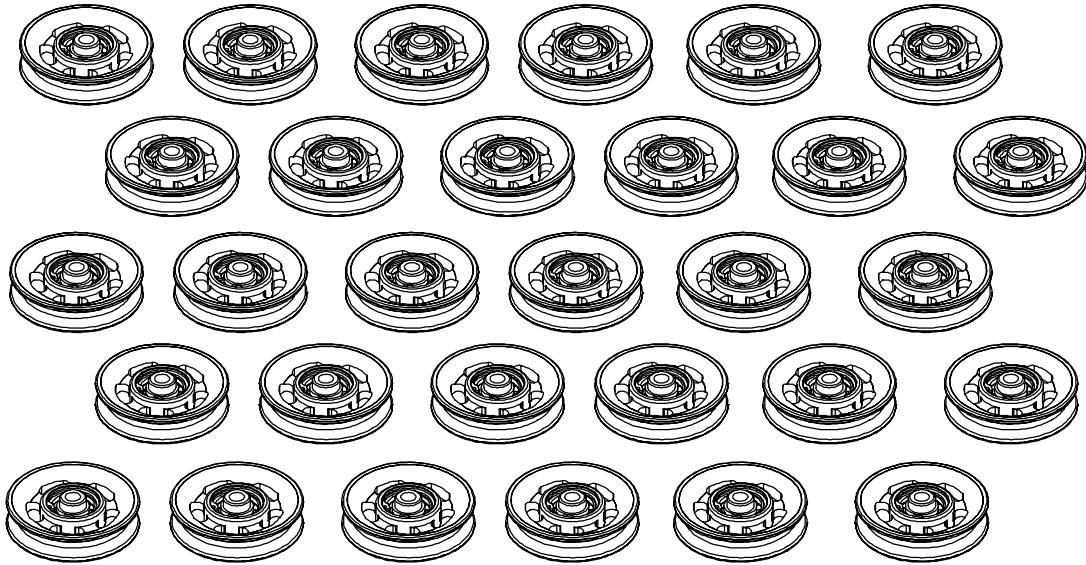

**28**  
x1

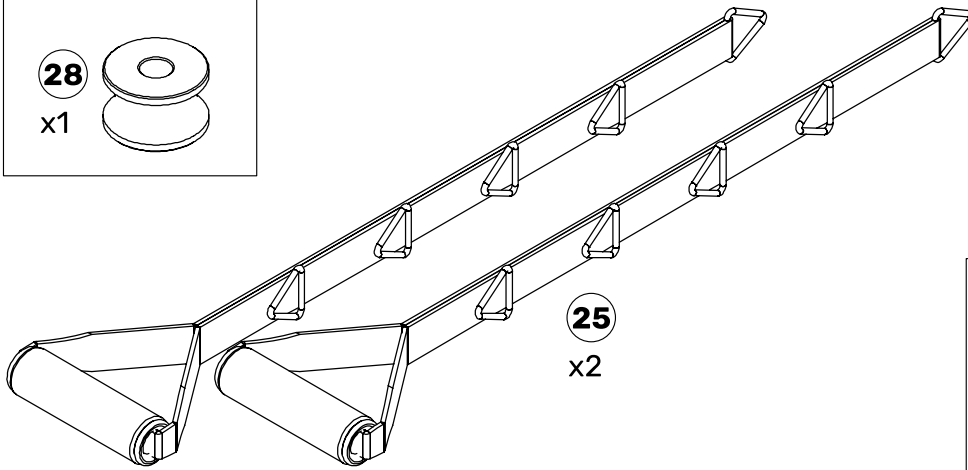
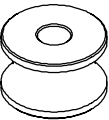

**25**  
x2

**26**  
x2

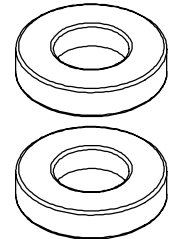

**27**  
x2

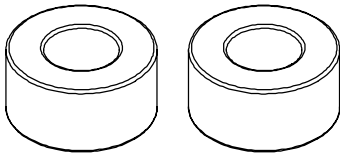

**29** x5

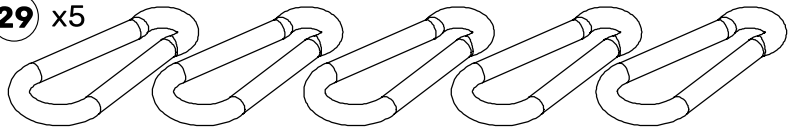

**30** x1

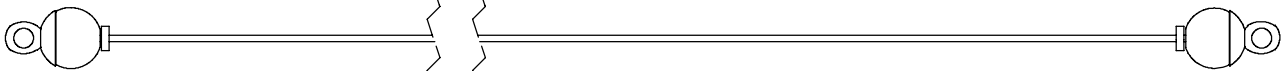

**31** x1

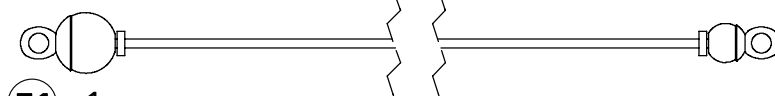

**32** x1

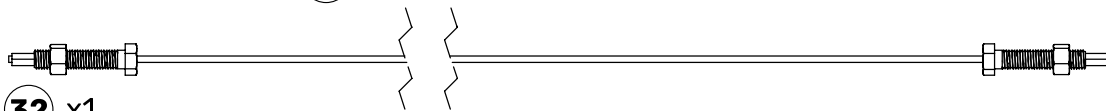

# PARTS LIST

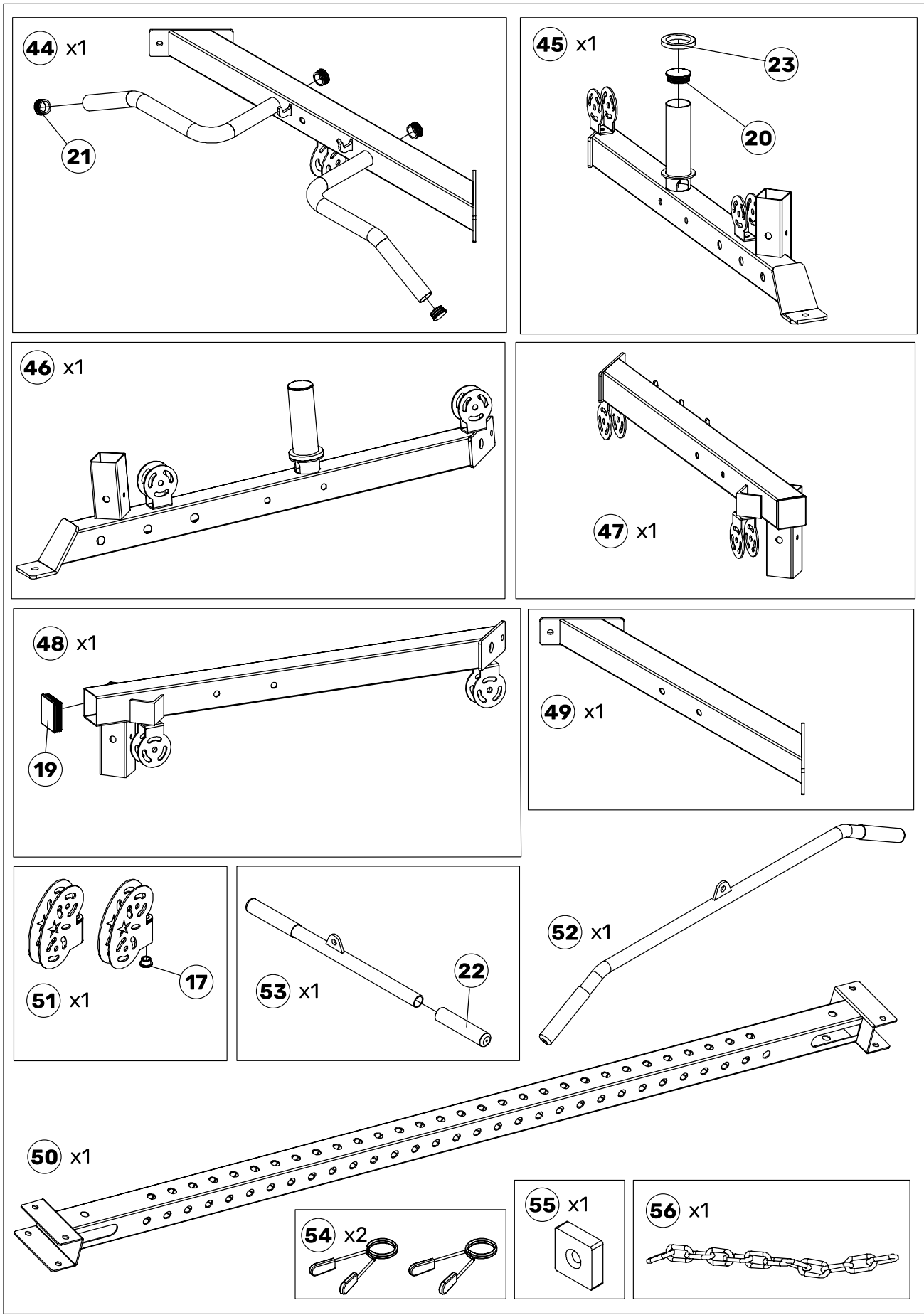

## TOOLS REQUIRED

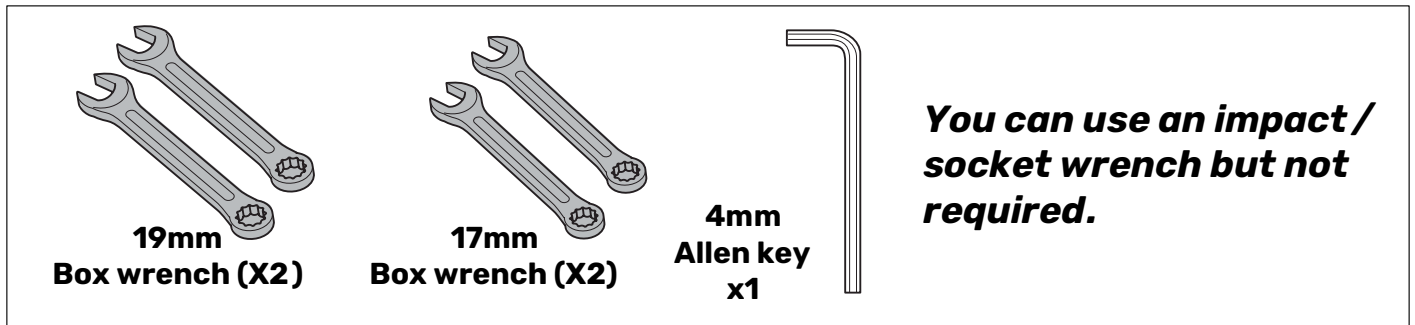

## ASSEMBLY

**PRO TIPS:** For easier assembly, group the hardware together for each step. Group the bolts, washers and nuts according to sizes. (M12 bolt, M12 washer, M12 nut), (M10's).

- 1** Attach (55) to bottom of (34) using M10 x 25mm countersunk bolt (8).

- 2** Connect (34) and (49) with (33). Fix M10 x 80 bolt (3), M10 washer (12), and M10 nut (10).

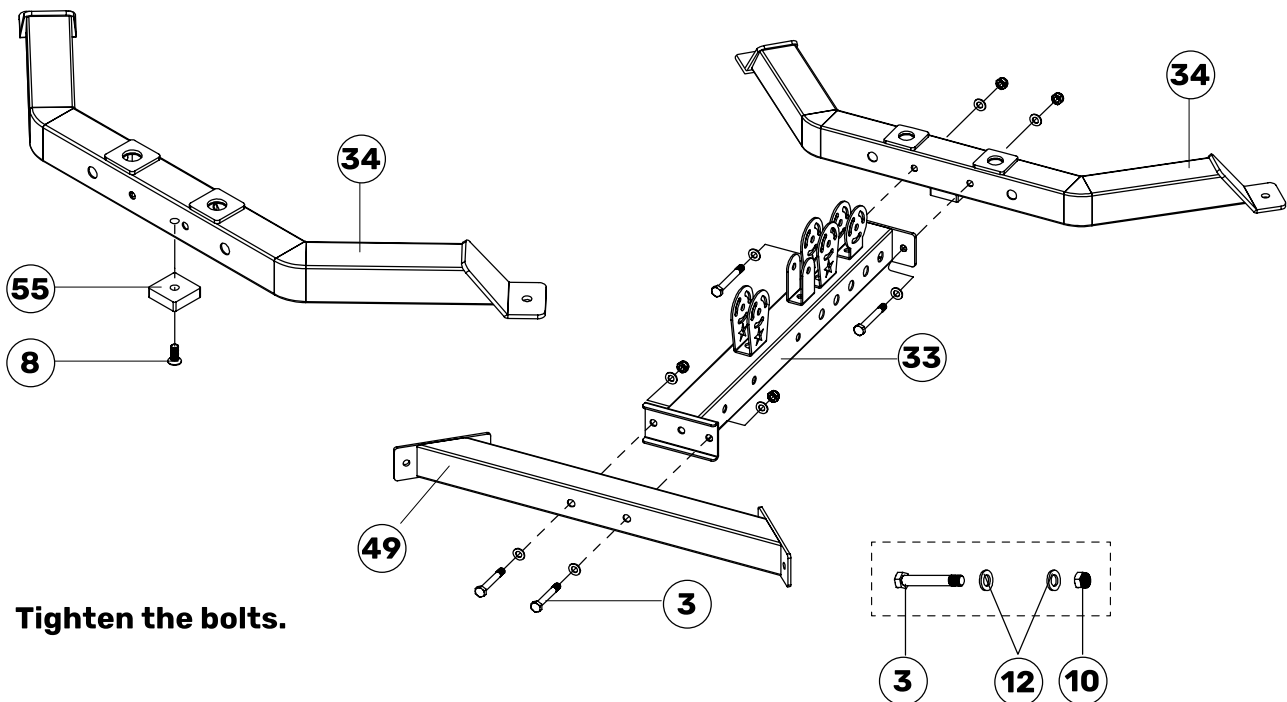

# ASSEMBLY

**3**

Fix the rod (39) using M10 x 20mm bolt (7) and M10 washer (12). Add (26), (36) and (27).

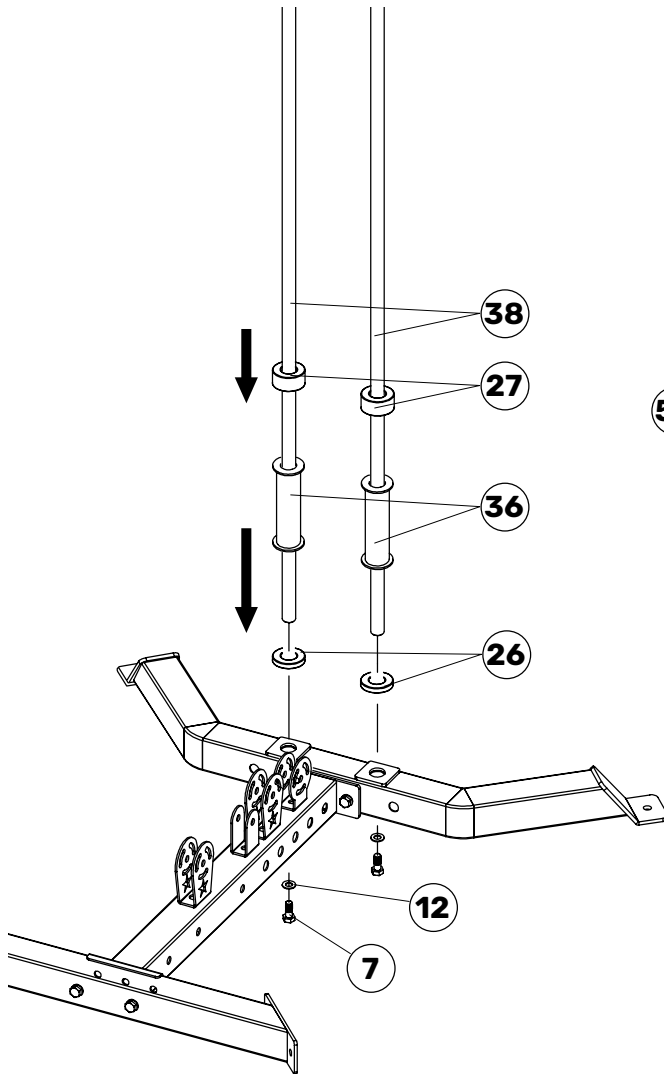

**4**

Attach upright (50), fix with M10 x 80 bolt (3), M10 washer (12), and M10 nut (10).

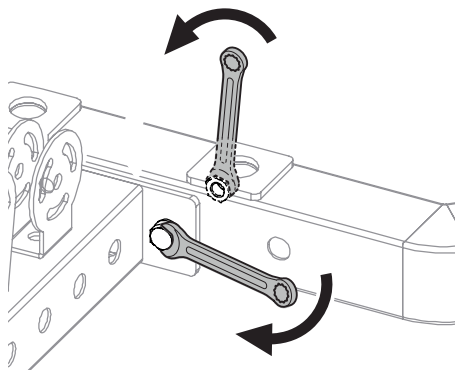
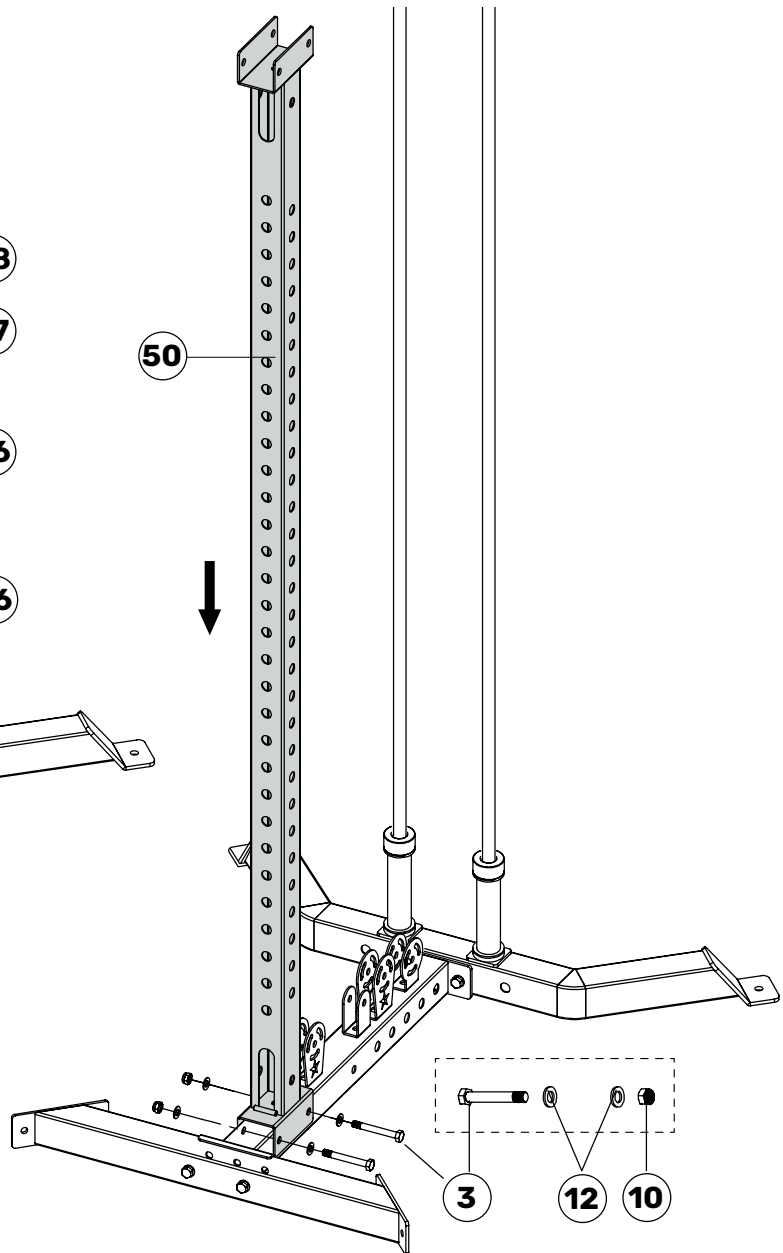



# ASSEMBLY

- 5** Attach pre-assembled base support (45) & (46). Fix with with M10 x 80 bolt (3), M10 washer (12), and M10 nut (10). Also M10 x 75 (4) bolt and M10 washer (12). M10 x 80 bolt (3), M10 washer (12), and M10 nut (10) for the middle.

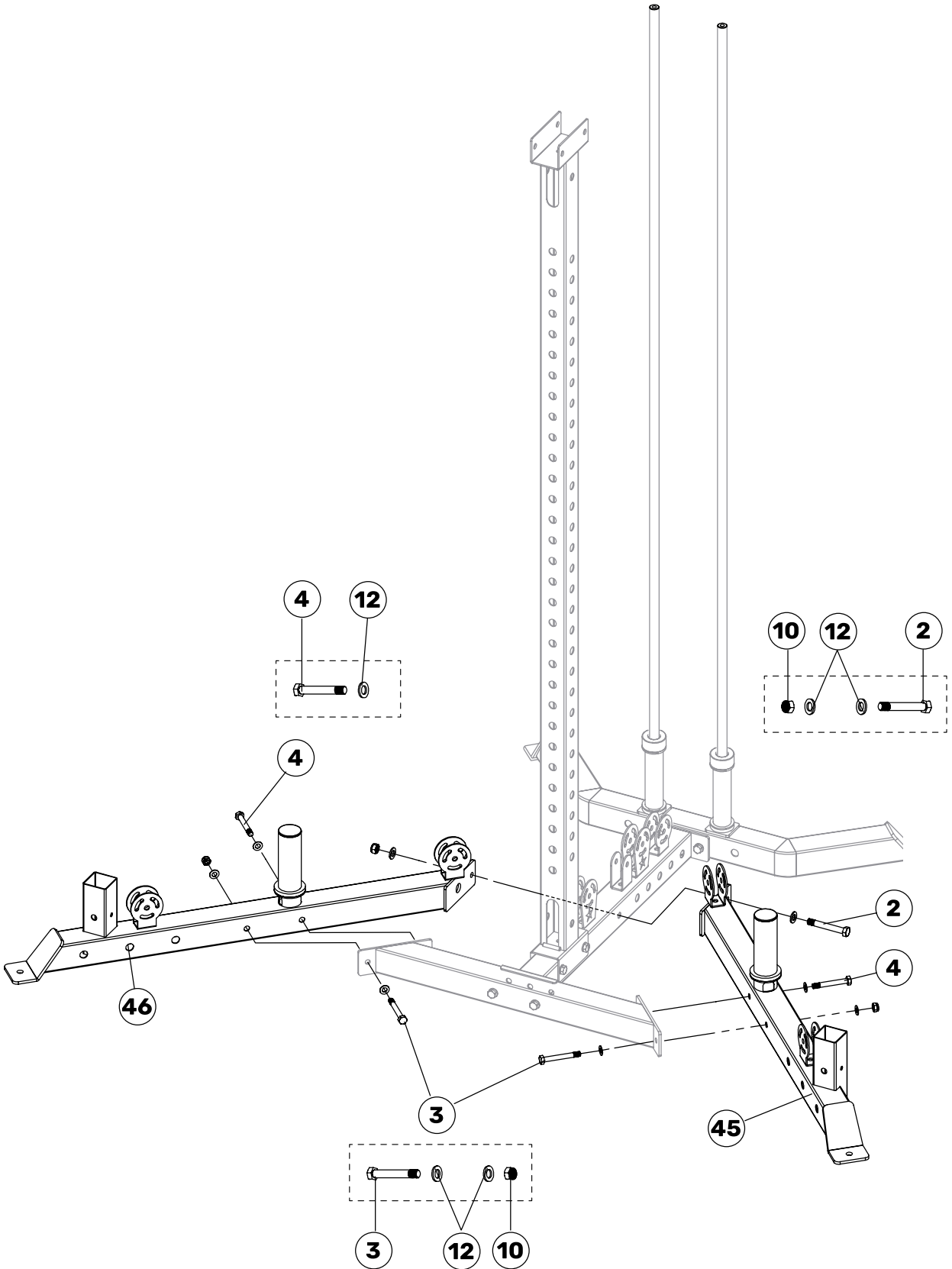

- 6** Insert side uprights (40). fix with M10 x 70 bolt (5), M10 washer (12), and M10 nut (10) and M10 x 20 (7) set with M10 washer(12).

Slide in pre-assembled (42).

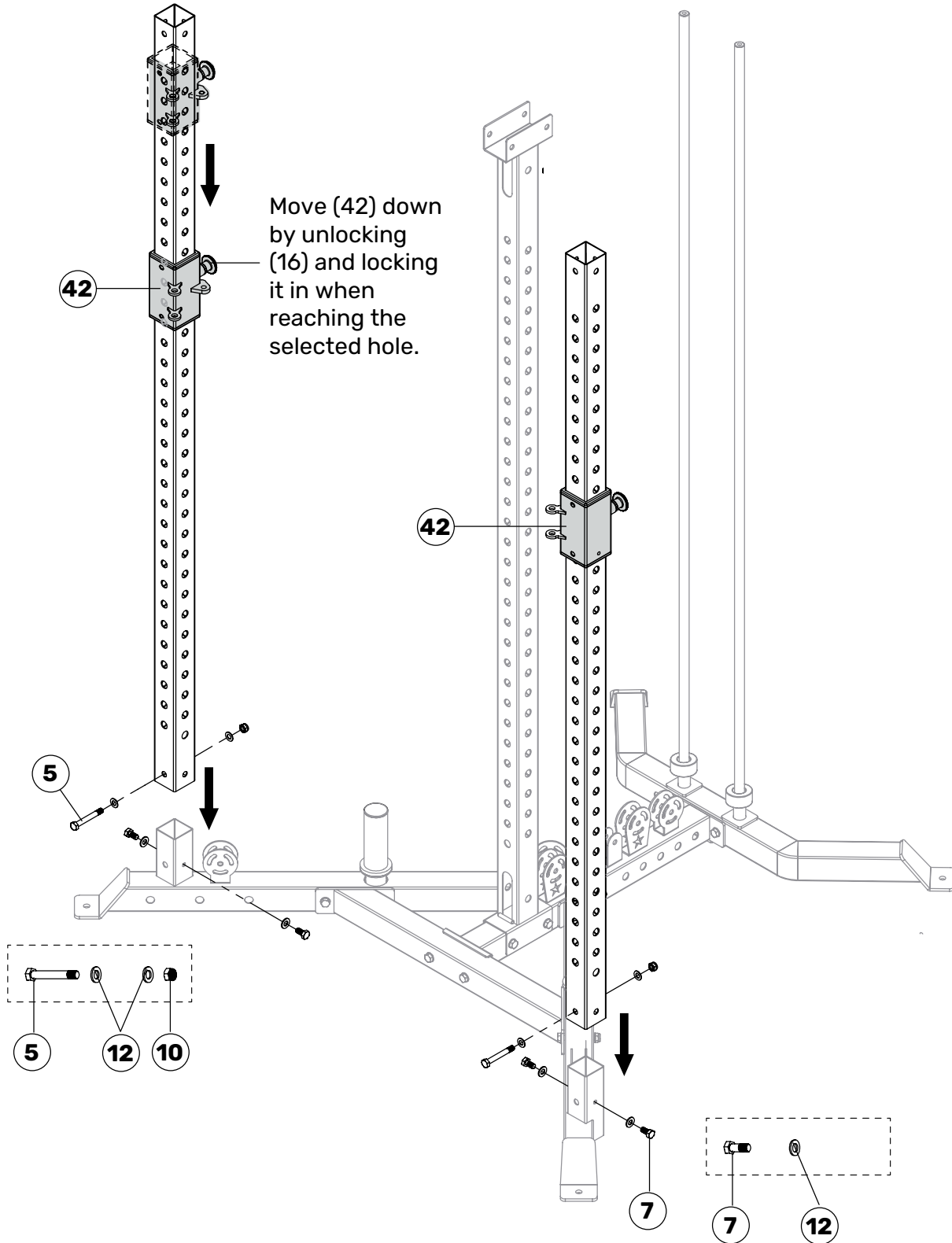

**7**

Add (23) and (54) to pre-assembled (41).

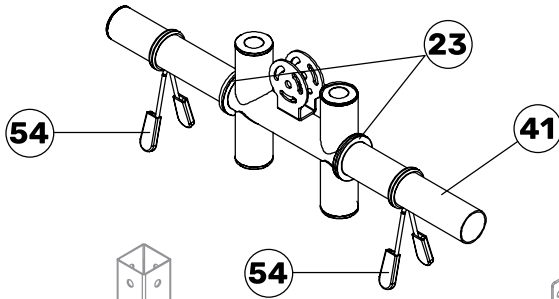

**8**

Slide on plate trolley.

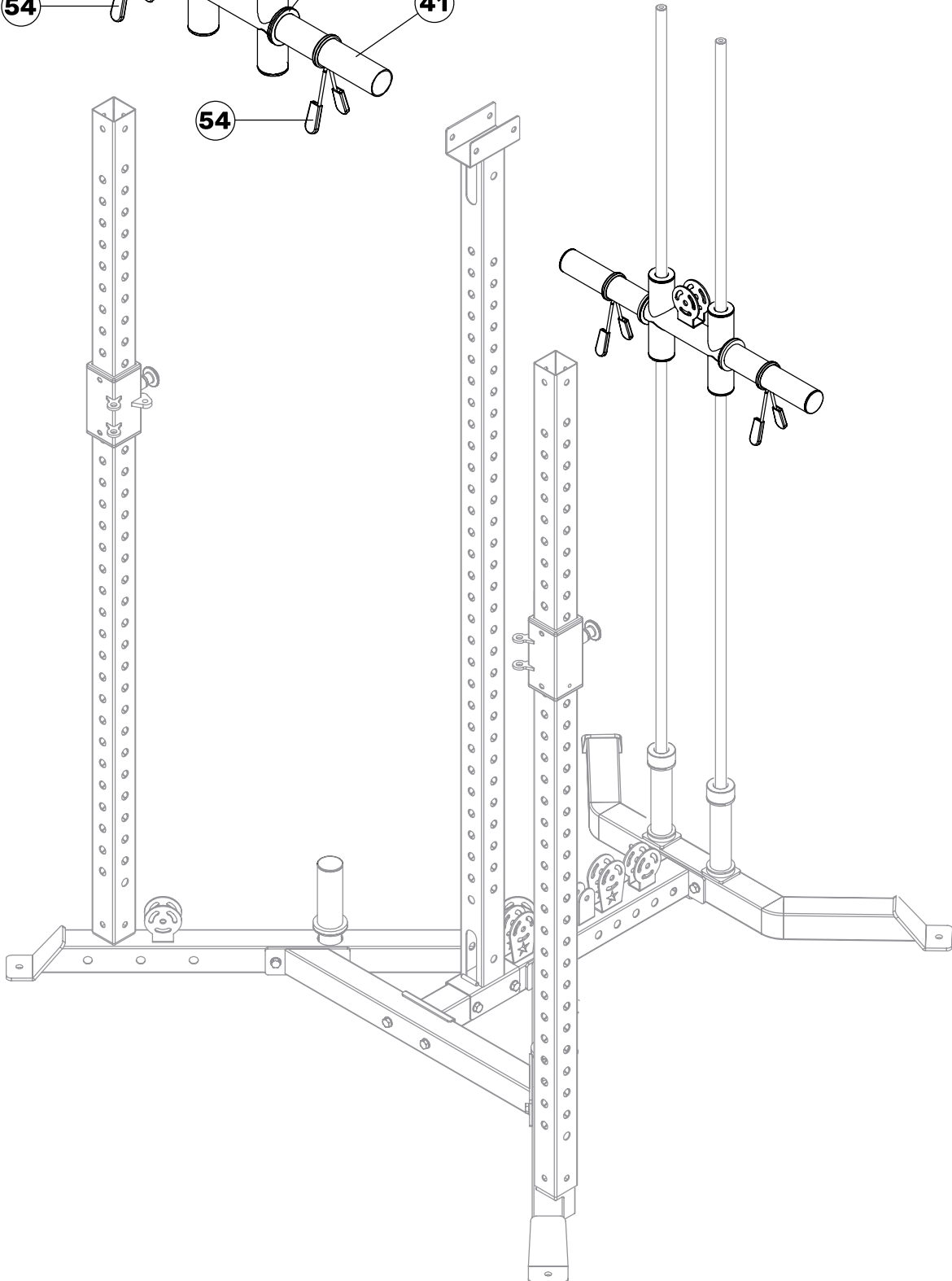

**9** Attach top support (35), fix with M10 x 80 bolt (3), M10 washer (12), and M10 nut (10).

Install pre-assembled height selector (51) to both side uprights and fix with M12 x 80 bolt (3), M12 washer (11), and M12 nut (9).

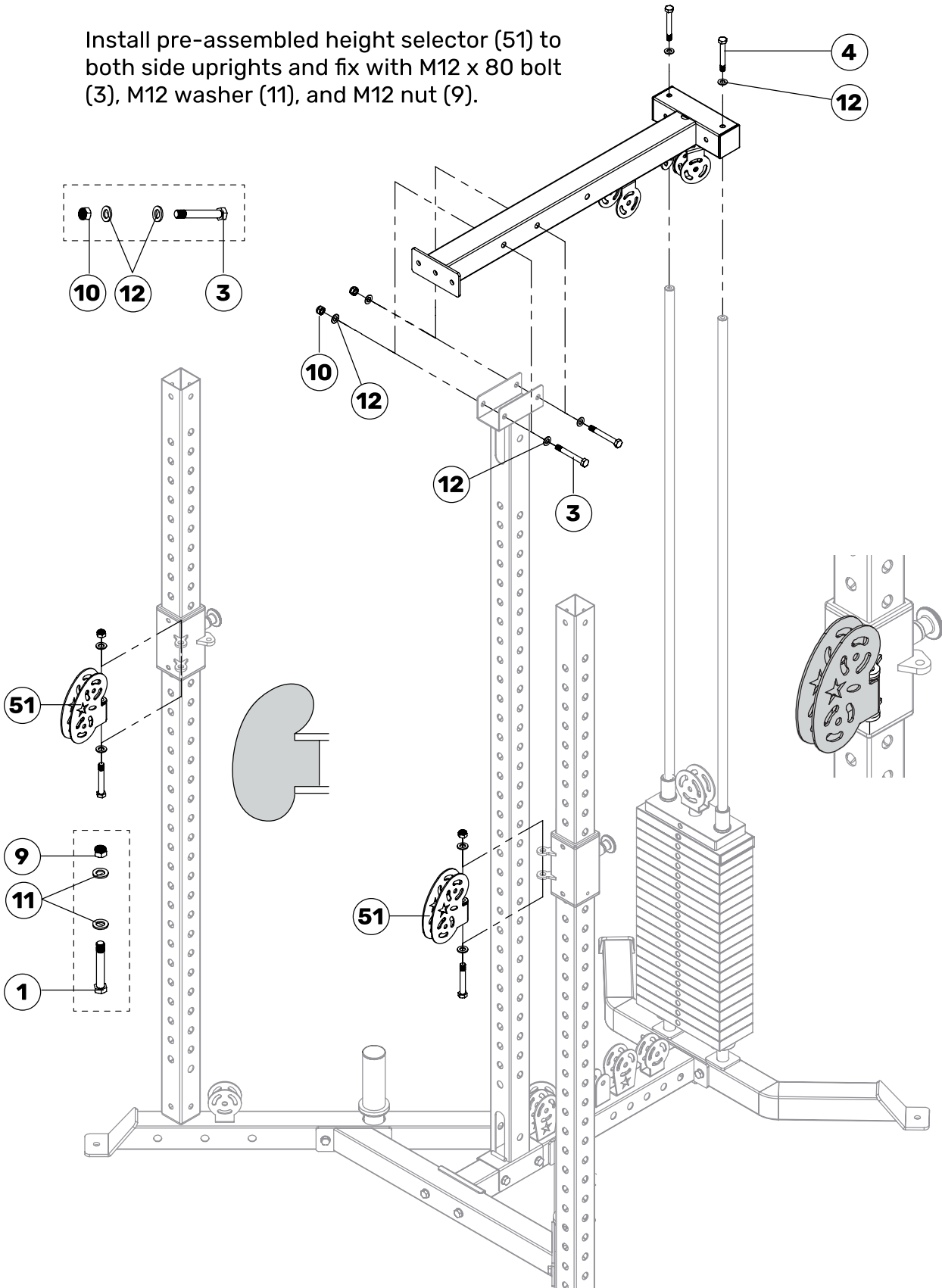

# ASSEMBLY

**10** Attach top side supports, (47) & (48).  
Fix M10 x 80 bolt (3), M10 washer (12),  
and M10 nut (10).

Also use M10 x 85 bolt (2), M10  
washer (12), and M10 nut (10) and  
M10 x 20 bolt (7), M10 washer (12).

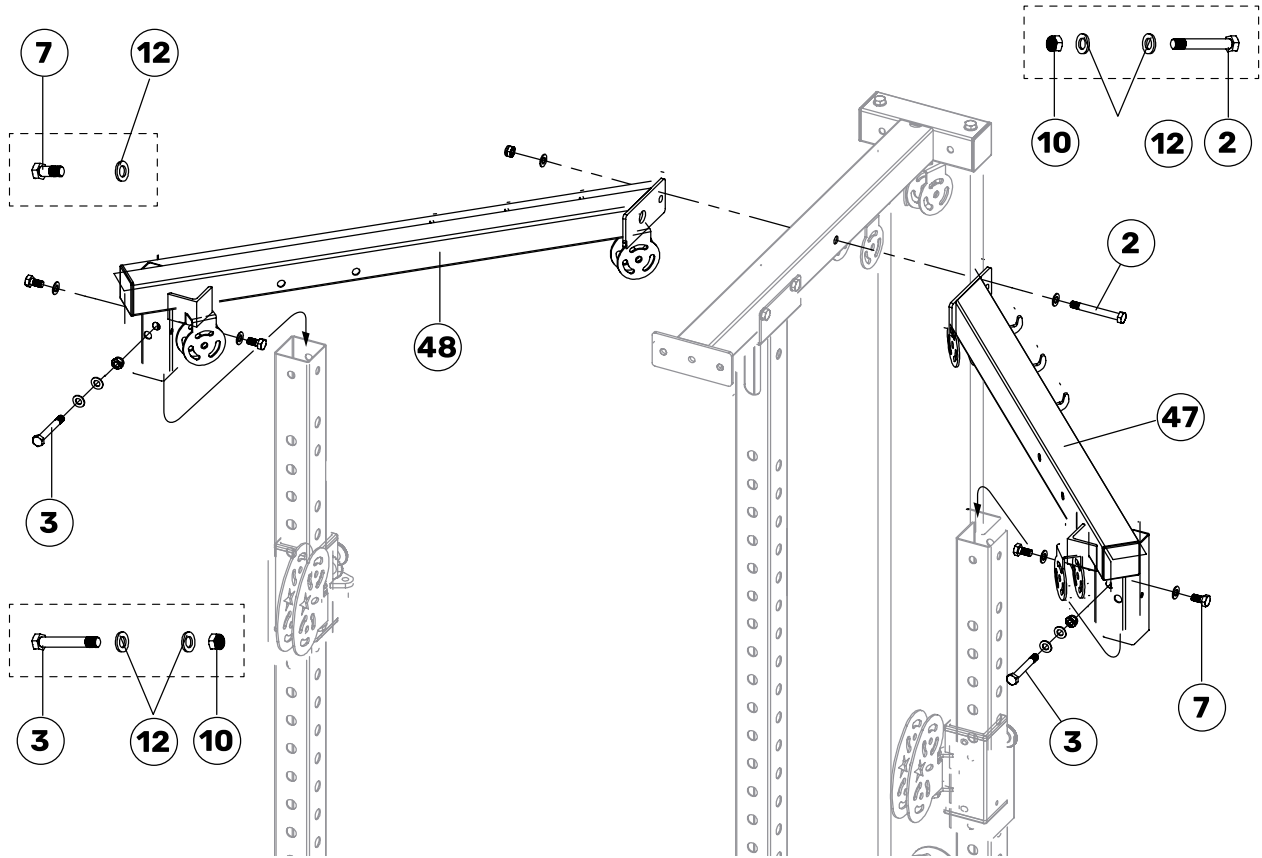

**11** Attach front support (44) fix with M10 x 80 bolt (3), M10 washer (12), and M10 nut (10) set, and M10 x 75 bolt (4), M10 washer (12) set.

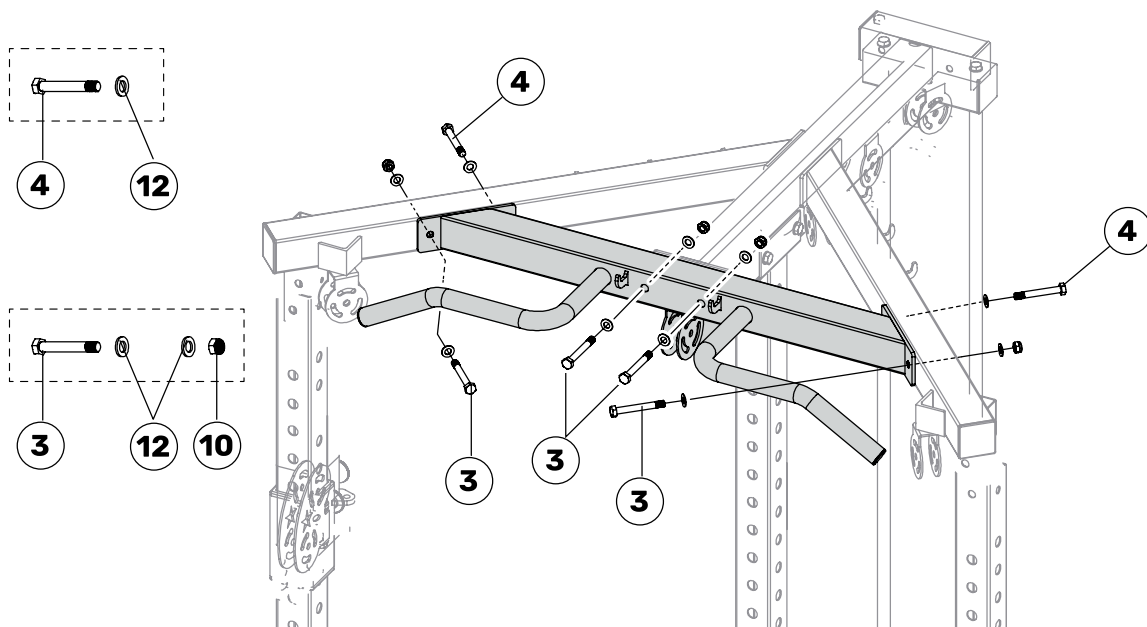

- 15** Attach pulley holders (43) and (37) with two pulleys (24) on the upper holes. Fix with M10 x 70 bolt (5), M10 washer (12), and M10 nut (10).

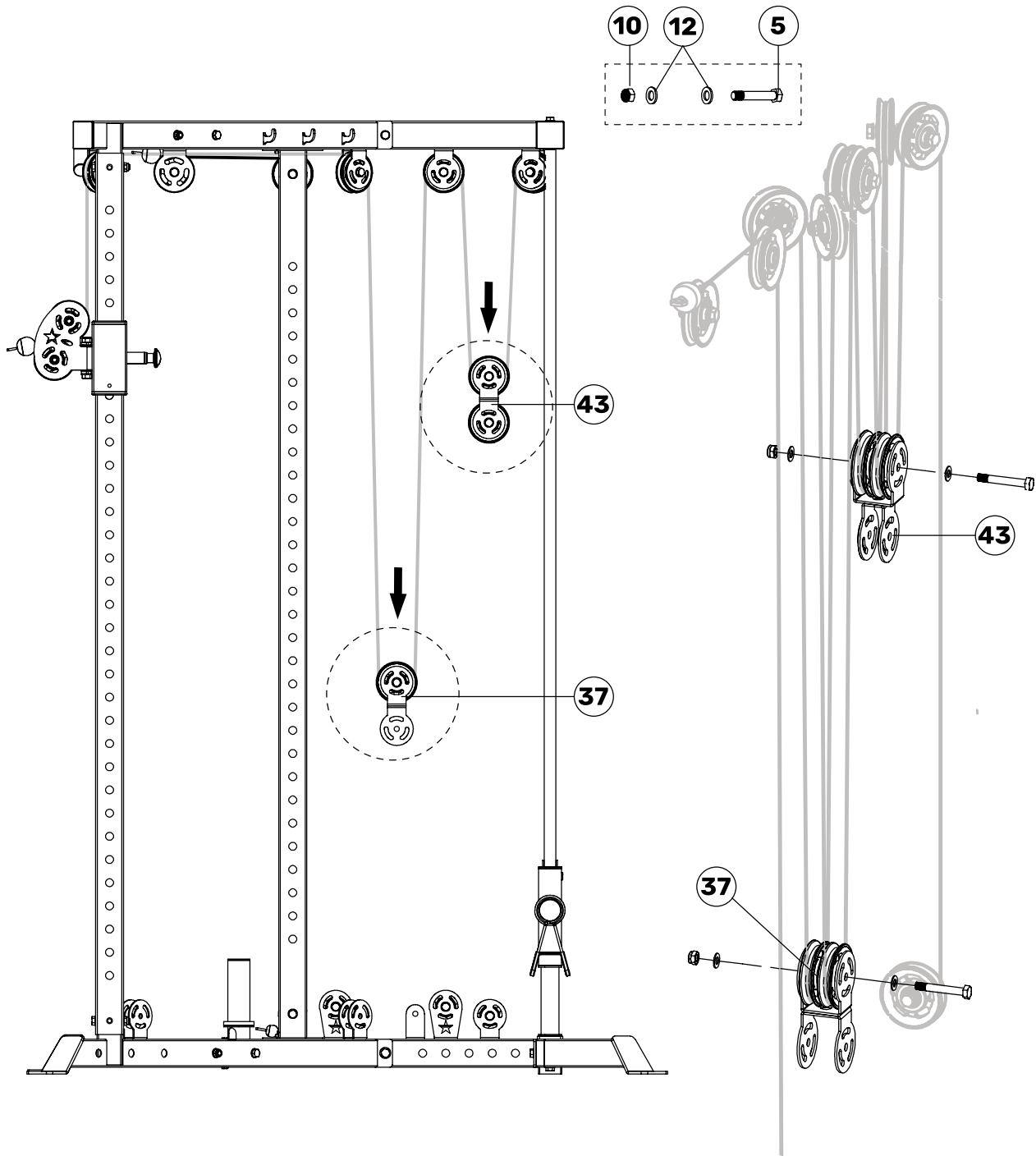

## 16

Cable 2 (31)

Start **12** by fixing a pulley and cable (31). Secure with M10 x 45 bolt (6), M10 washer (12), and M10 nut (10).

Attach another pulley with the cable through the upright **13**. Secure with M10 x 80 bolt (3), M10 washer (12), 2 10x16-17 pulley sleeve (13) and M10 nut (10).

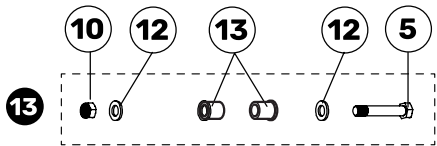
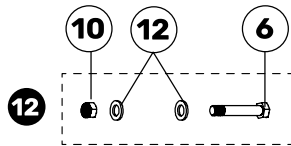
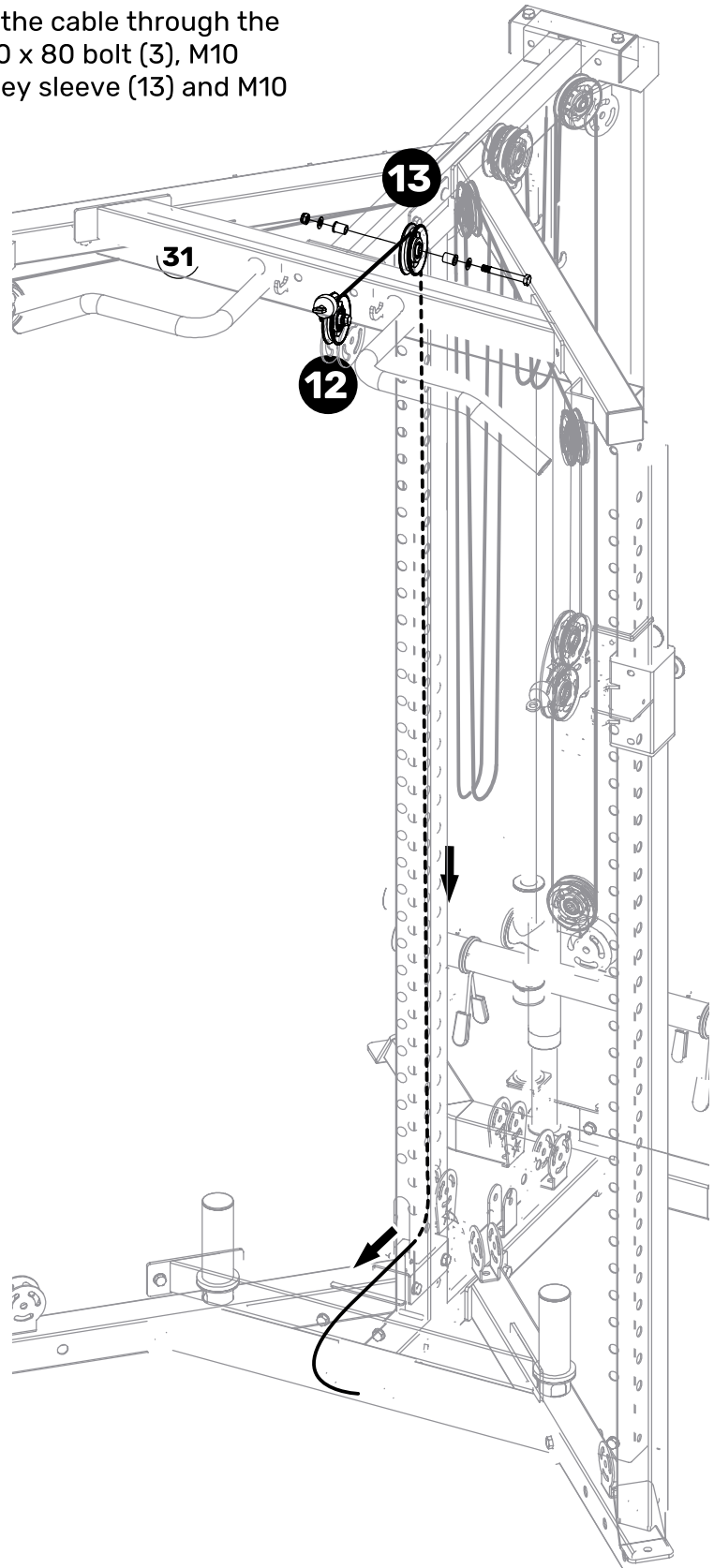

**17** Pull the end of cable through the upright's lower hole. Then slowly pull the middle back to the weight stack's direction.

**18** Attach a pulley and M10 set above the cable. Fix M10 x 45 bolt (6), M10 washer (12), and M10 nut (10).

Attach a pulley and M10 set on **12** (lower hole of pulley holder). Fix M10 x 45 bolt (6), M10 washer (12), and M10 nut (10).

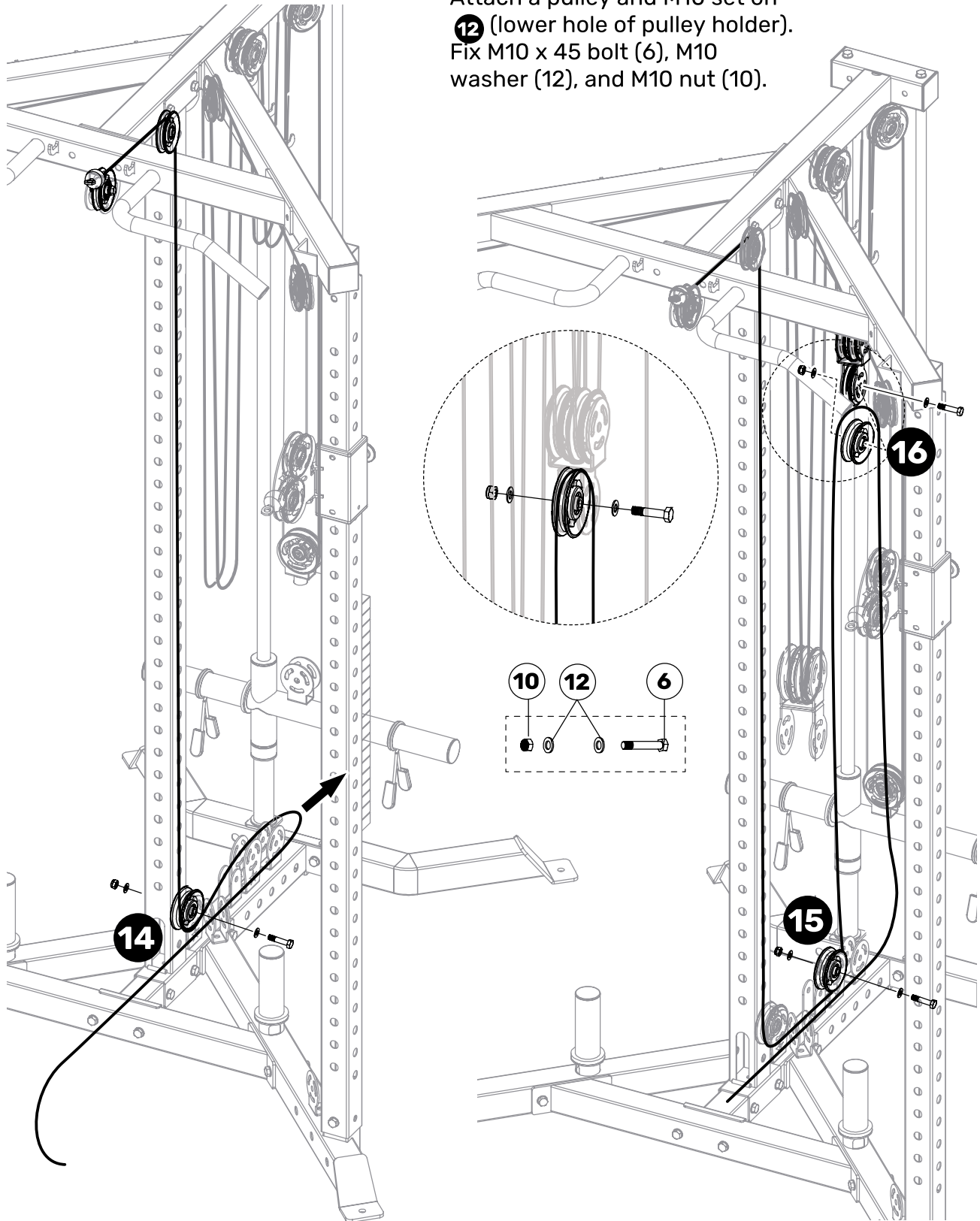



- 19** Add 2 more pulley and fix it with M10 x 45 bolt (6), M10 washer (12), and M10 nut (10).

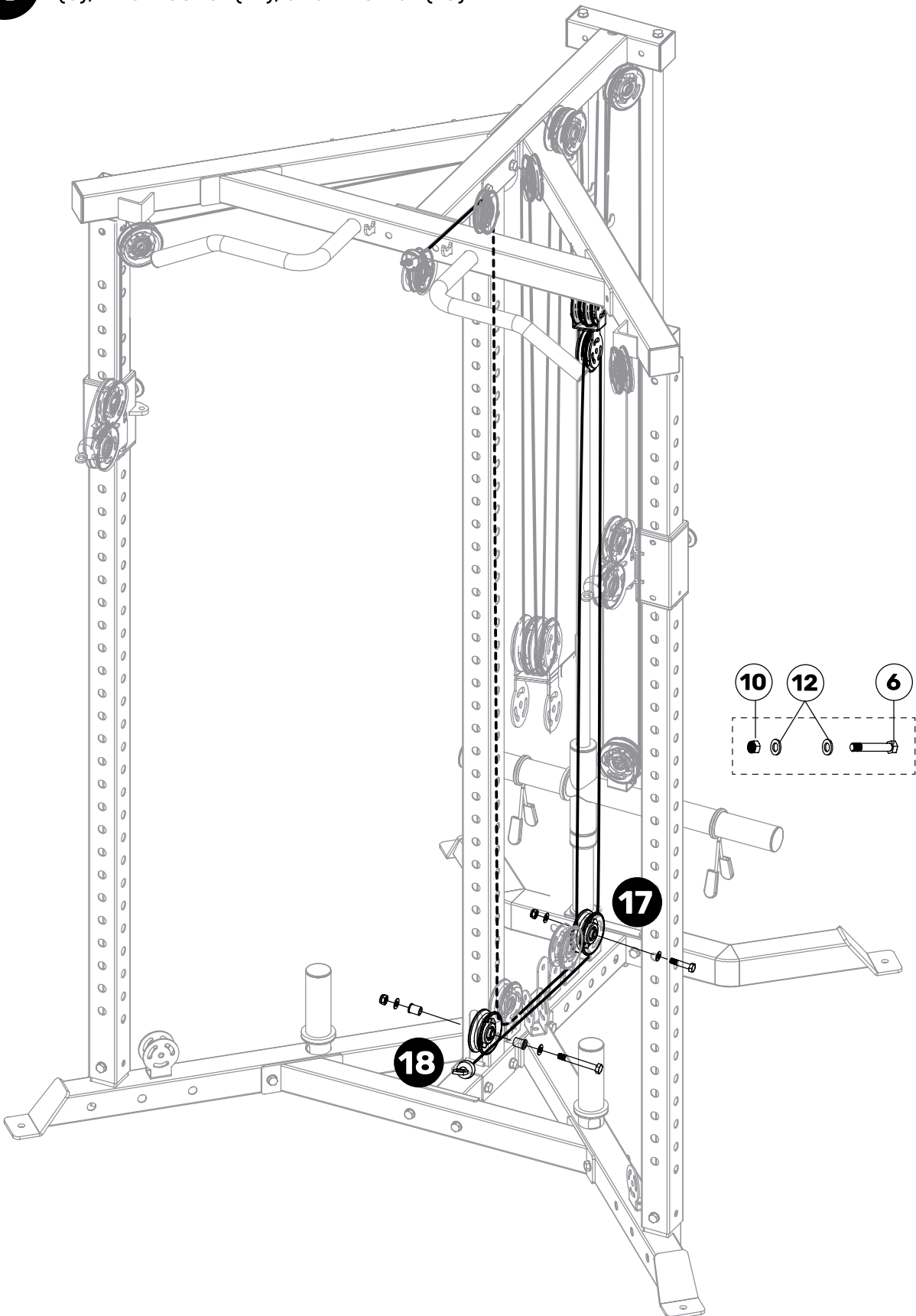

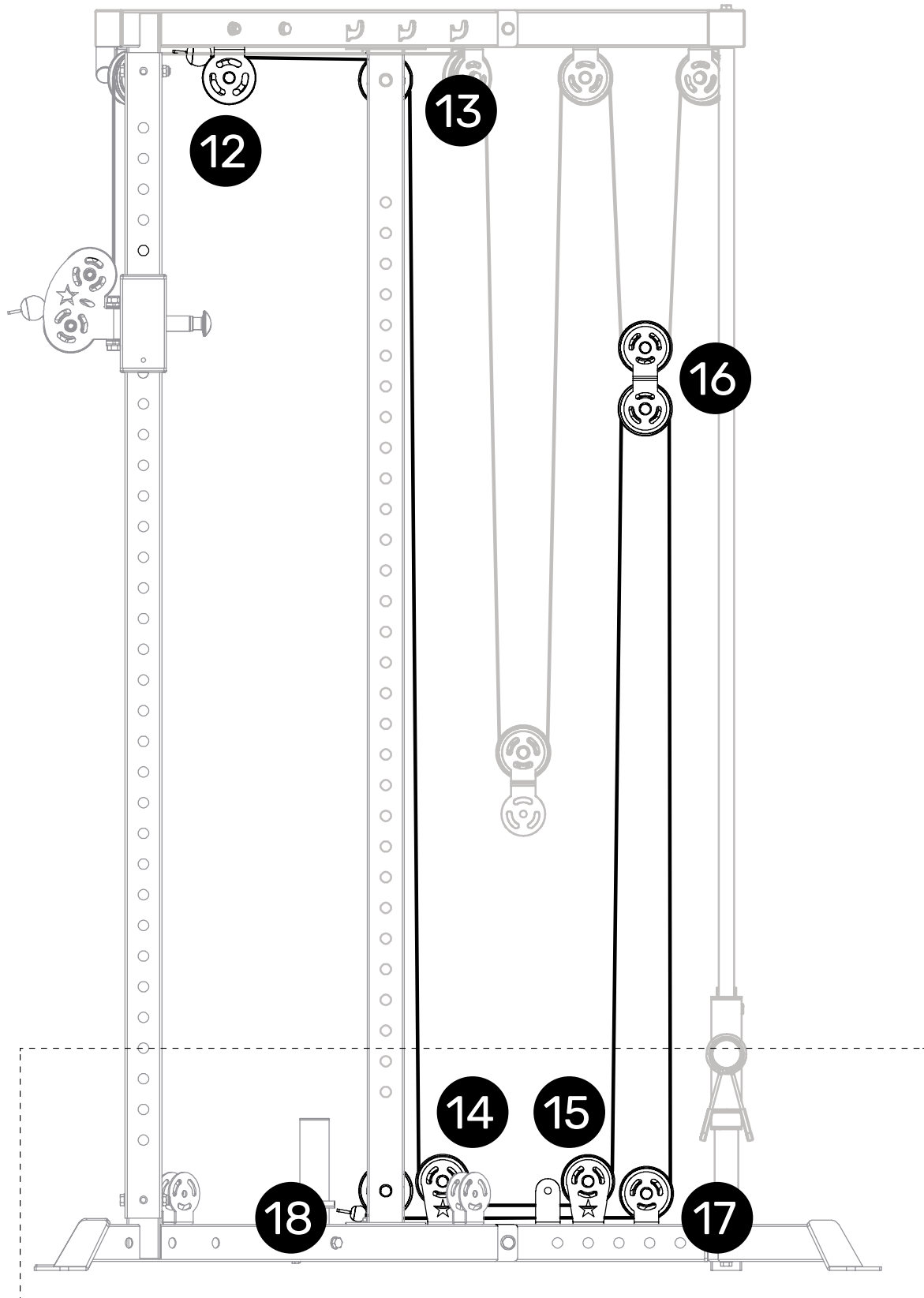

Make sure cables installed in 14, 15, 17, 18 are not overlapping/ intertwined. This will cause premature wear on the cable and throw of the resistance of the weights.

**20**

**Cable 3 (32)**

Bolt in the end of cable (32) at the side of (42) nice and tight. At **Step 19**. Add a pulley at the bottom and M10 x 45 bolt (6), M10 washer (12), and M10 nut (10).

**Repeat for the other side.**

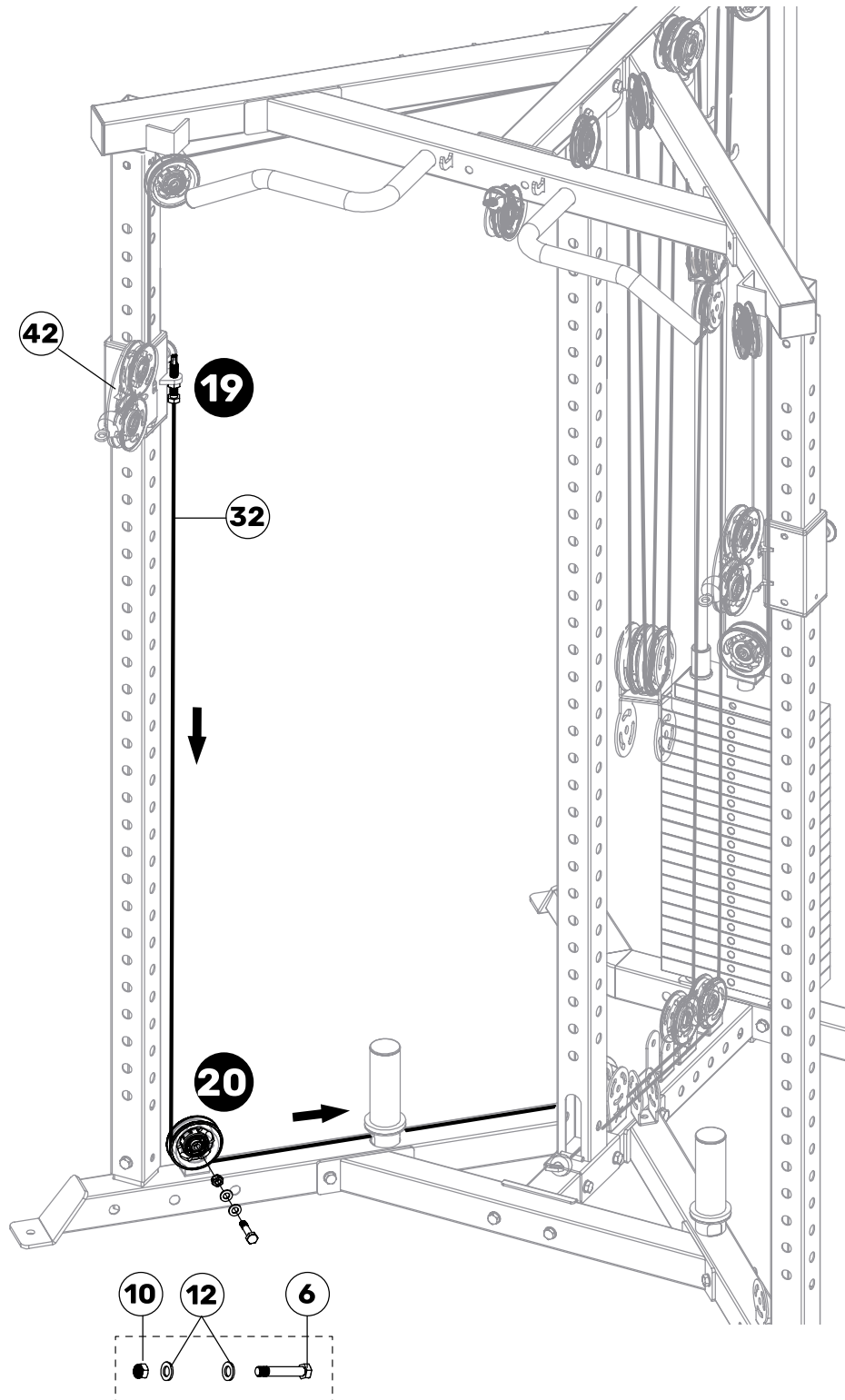

**21** Attach other pulley on step **21**. Fix with M10 x 45 bolt (6), M10 washer (12), and M10 nut (10).

Attach 2 pulleys on step **22**. Pass the cable through one of the pulley. Fix with M10 x 70 bolt (5), M10 washer (12), and M10 nut (10).

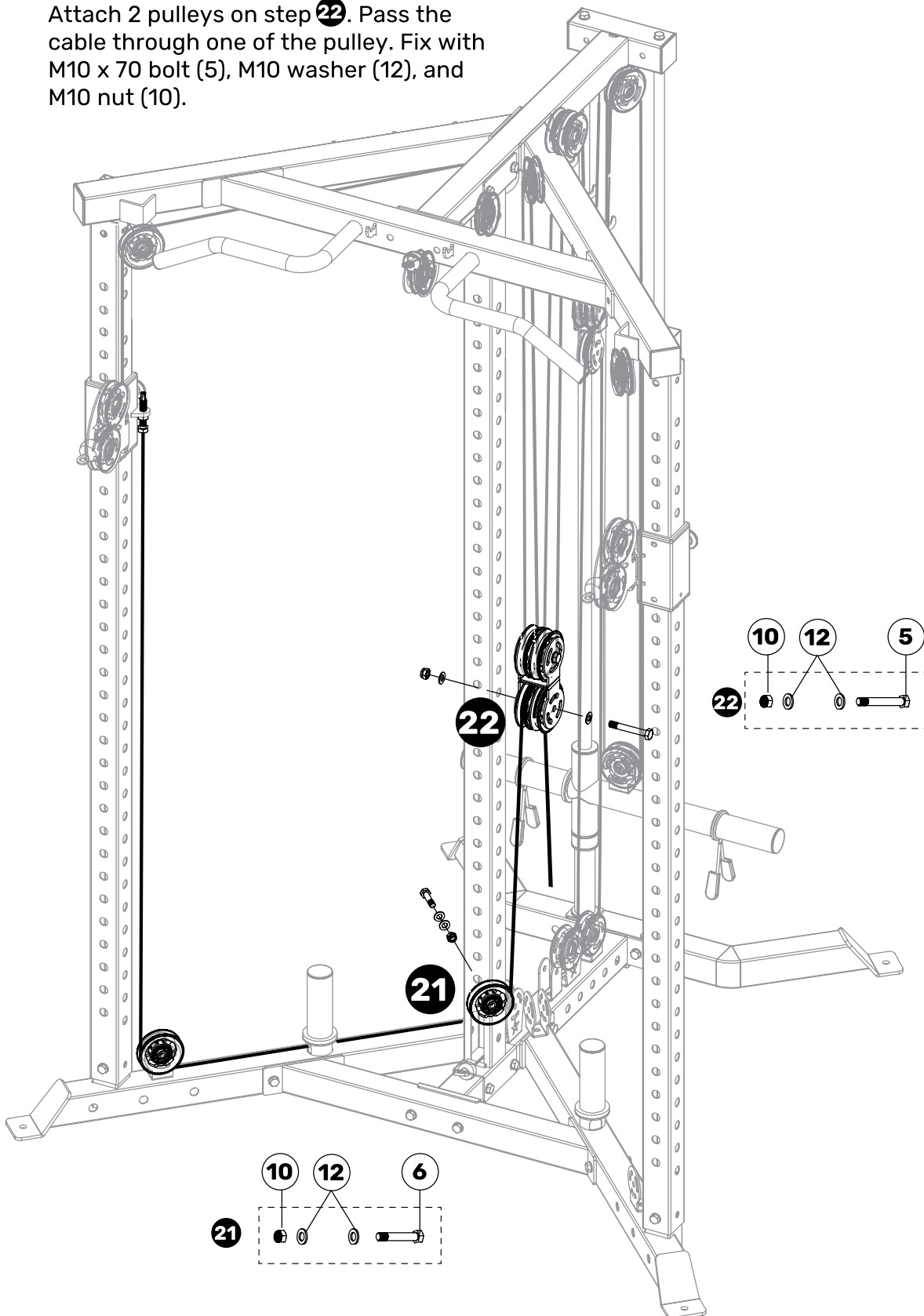

**22** Attach (28), fix with M10 x 45 bolt (6), M10 washer (12), and M10 nut (10).

Run the end of cable back to hanging pulley.

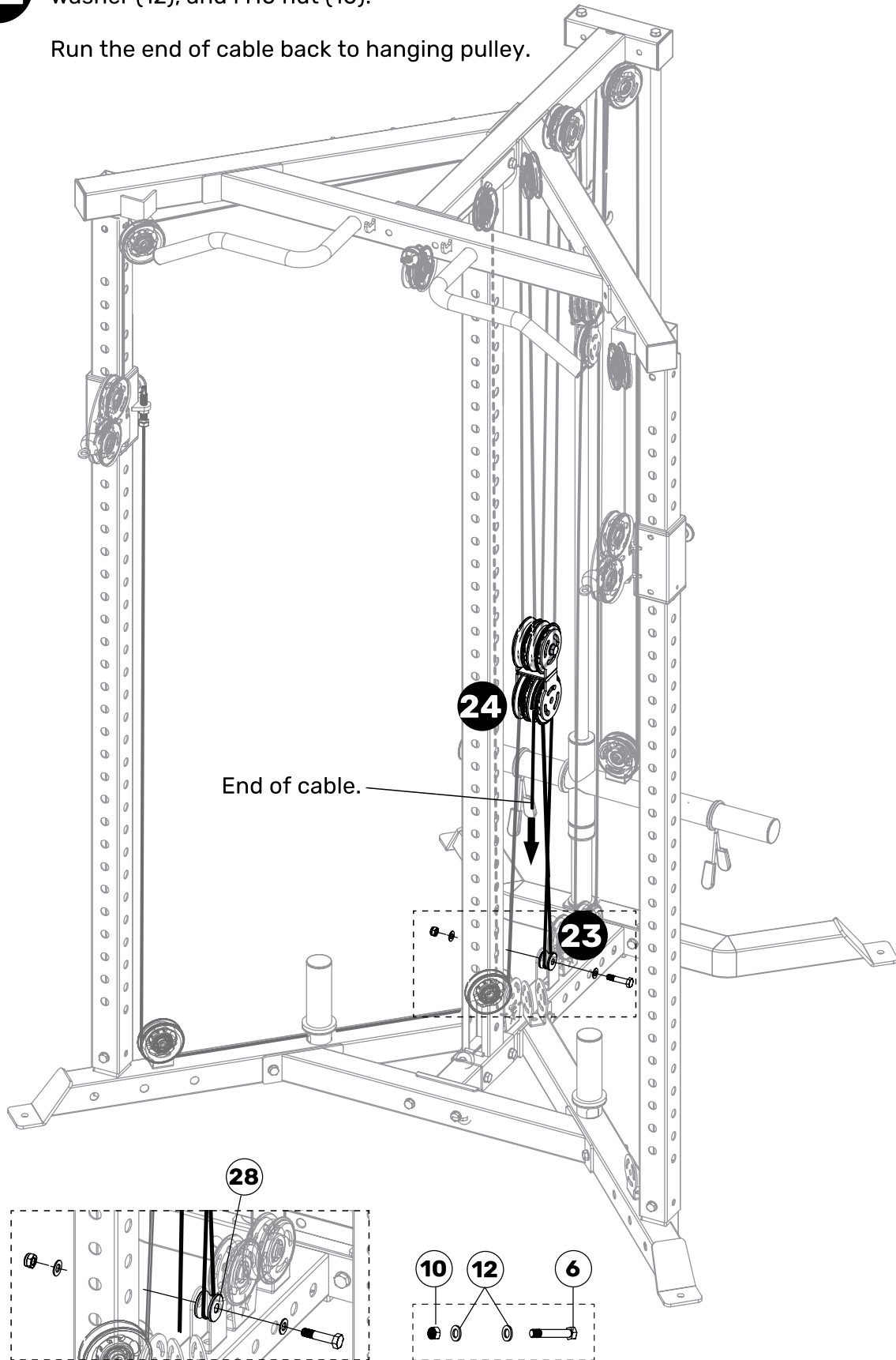

**23** Add other pulleys on step 25 and 26. Fix with M10 x 45 bolt (6), M10 washer (12), and M10 nut (10).

Bolt in the end of the cable on (42).

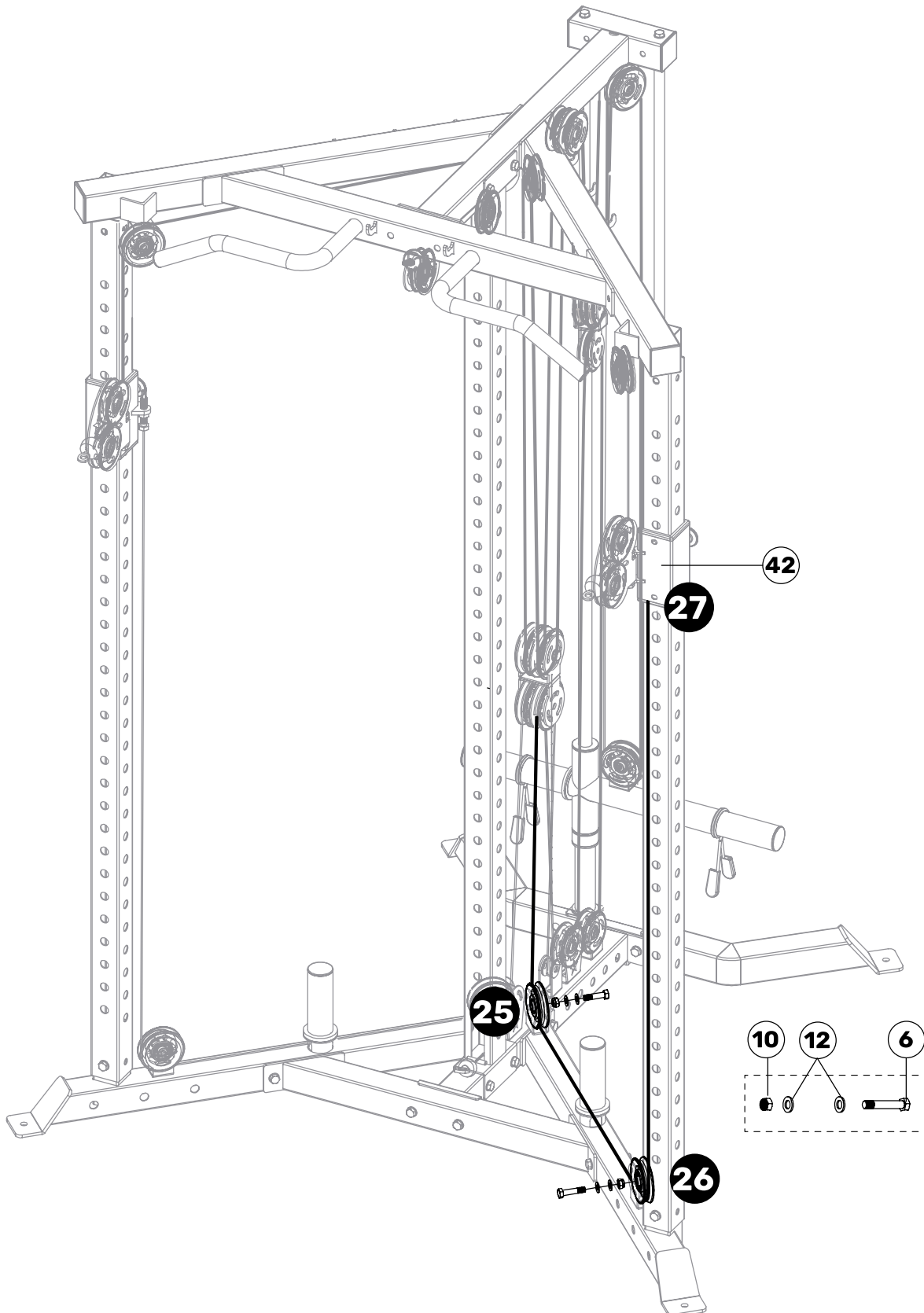

24

Attach remaining parts as shown.

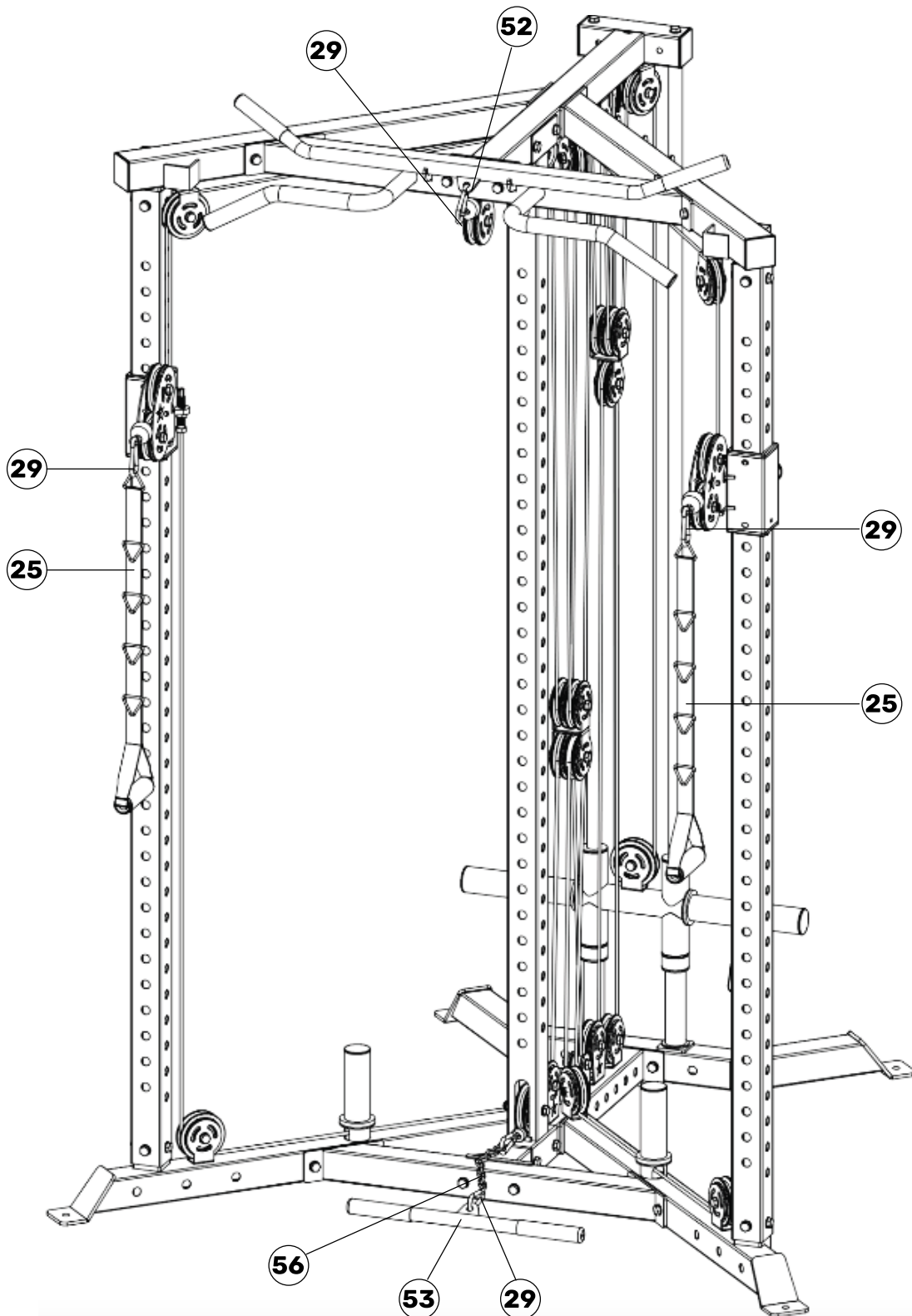

# YOU'RE FINISHED!

**WANT TO LEARN MORE ABOUT THE PLATE LOADED ALL-IN-ONE TRAINER? CHECK OUT THE OVERVIEW VIDEO:**



## VISIT OUR SHOWROOMS



Calgary - HQ



Toronto - Showroom



Indianapolis - Showroom

Corporate Headquarters 7880 66 St SE, Calgary, AB, Canada

U.S.A. Headquarters 5925 W 71st St, Indianapolis, IN, U.S.A.

Toronto Store 39 Haist Ave # 2, Woodbridge, ON, Canada

[support@bellssofsteel.com](mailto:support@bellssofsteel.com) | 1-888-718-7997