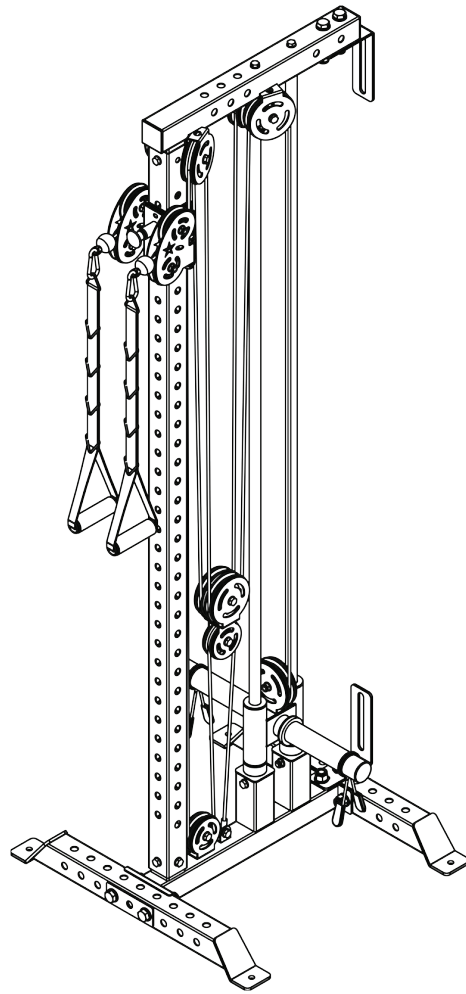



**PLATE-LOADED  
CABLE TOWER  
SKU: PULT4-MA  
PO:**



## ASSEMBLY INSTRUCTIONS

   **BELLSOFSTEEL**

**Stuck?** Scan the QR code for the assembly video

[www.bellsofsteel.com](http://www.bellsofsteel.com) | [www.bellsofsteel.us](http://www.bellsofsteel.us) | Telephone: 1-888-718-7997



# BUILDING STRENGTH, ONE BOLT AT A TIME.



## Welcome to Bells of Steel, you've made an excellent choice.

First off I want to say thank you for supporting my small business.

I've put significant thought into designing this product to enhance your lifting experience and help you reach your full potential. I hope you love it!

I've done my best to keep the setup of your new gear simple. If you find yourself needing a bit more assistance than the included instructions, check our youtube page for assembly videos or feel free to email us for troubleshooting guidance.

**Kaevon Khoozani**



Crush your Gains! Subscribe to our YouTube for workouts & how-to's.

**@BELLSOFSTEEL**



Warranty & returns? We got you covered—check here:

**[bellssofsteel.com/pages/warranty](https://bellssofsteel.com/pages/warranty)**

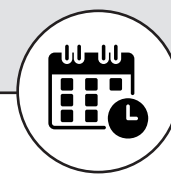

Changed your mind? No sweat. 30-day refund guarantee:

**[bellssofsteel.com/policies/refund-policy](https://bellssofsteel.com/policies/refund-policy)**



### Let us know how we've done

Love it? Leave a review! Hate it? We still read it. Help us get better by reviewing our products.



### Customer Notice

If you are missing any parts, or otherwise have any warranty issues/shipping damages, please file a warranty claim on our website.

Before discarding the box, please take clear photos of the box and shipping labels, as these may be required if parts are missing or the item is damaged.

# BEFORE WE BEGIN, LET'S STAY SAFE.



## A GUIDE TO SAFETY

---

We know you are excited to use your new Bells of Steel gear, but please read through this Guide to Safety to ensure you do not hurt yourself or others while exercising. It is your responsibility to ensure that all users of the equipment are informed of all warnings and instructions in this manual. TO REDUCE THE RISK OF SERIOUS INJURY, READ THE FOLLOWING IMPORTANT PRECAUTIONS BEFORE USING YOUR BELLS OF STEEL PRODUCT.







- ① Before starting any exercise program consult your physician. Be aware of your body's signals. Incorrect or excessive exercise can be damaging to your health. STOP EXERCISING IF YOU EXPERIENCE ANY OF THE FOLLOWING SYMPTOMS: PAIN, TIGHTNESS IN YOUR CHEST, IRREGULAR HEARTBEAT, SHORTNESS OF BREATH, LIGHTHEADEDNESS, DIZZINESS, OR FEELINGS OF NAUSEA. IF YOU EXPERIENCE ANY OF THESE SYMPTOMS, STOP EXERCISING IMMEDIATELY AND CONSULT YOUR PHYSICIAN BEFORE CONTINUING WITH YOUR EXERCISE PROGRAM.
- ② It is your responsibility to ensure there is enough space around the product for the intended exercise. Use the product on a flat surface and ensure at least 2 feet (60 cm) of free space around it.
- ③ Children and pets must not be let on or near the product. Moving parts and heavy features of the product can be dangerous and cause serious injury.
- ④ Read all instructions in this manual before using the product and use the product only as described in this manual.
- ⑤ It is your responsibility to ensure that all users of the product are adequately informed of all precautions, have read and understand all warnings, and are informed how to use the product properly.
- ⑥ Keep hands and feet from moving parts. Do not lean or rest on the product.
- ⑦ Wear athletic shoes for foot protection while exercising.
- ⑧ Your product is intended for use in cool, dry conditions. You should avoid storage in extreme cold, hot, or damp areas.
- ⑨ This product is designed for indoor use only.
- ⑩ Ensure that any weight pins that may be included with your product are completely inserted into an appropriate weight plate.
- ⑪ Ensure that any handles that may be included with your product are attached securely before using the product.
- ⑫ Ensure that any nuts and bolts that may be included with your product are securely tightened before use. Regularly re-tighten nuts and bolts.
- ⑬ Ensure any cables that may be included with your product always remain attached to their proper pulleys. If a cable bind occurs during exercise, stop immediately and inspect the part to ensure any interference is fixed.
- ⑭ Do not overexert yourself during any exercise program. Operate the product as intended.
- ⑮ The product should be anchored where required or whenever possible. The product should be secured when not in use.
- ⑯ The product is very heavy. Improper use or assembly can lead to serious injury or death.
- ⑰ SAVE AND REVIEW THESE INSTRUCTIONS.

NOW...

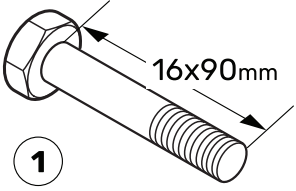
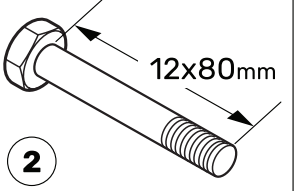
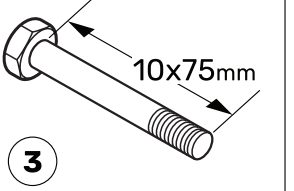
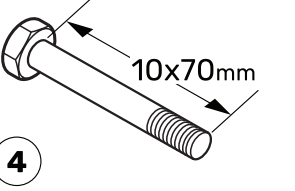
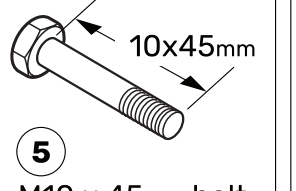
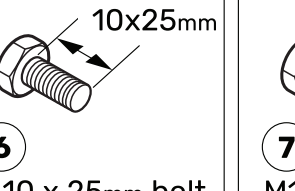
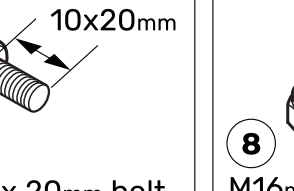

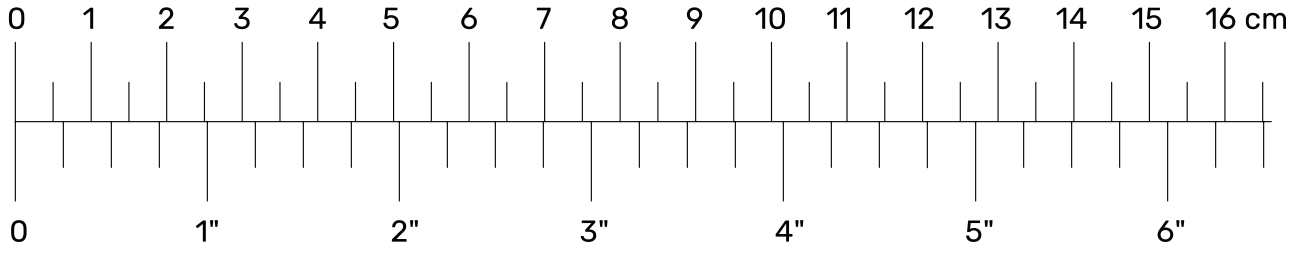

**LET THE GAINZ BEGIN**

# PARTS LIST

## • Hardware Package

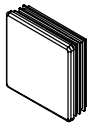
 <p><b>1</b> M16 x 90mm bolt x8</p>	 <p><b>2</b> M12 x 80mm bolt x2</p>	 <p><b>3</b> M10 x 75mm bolt x2</p>	 <p><b>4</b> M10 x 70mm bolt x5</p>	
 <p><b>5</b> M10 x 45mm bolt x12</p>	 <p><b>6</b> M10 x 25mm bolt x1</p>	 <p><b>7</b> M10 x 20mm bolt x2</p>	 <p><b>8</b> M16mm nut x8</p>	 <p><b>9</b> M12mm nut x3</p>
 <p><b>10</b> M10mm nut x14</p>	 <p><b>11</b> ∅ 16mm washer x16</p>	 <p><b>12</b> ∅ 12mm washer x5</p>	 <p><b>13</b> ∅ 10mm washer x36</p>	
				

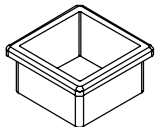
## • Preassembled

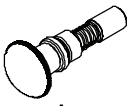
 <p><b>14</b> 12-19-24 power bearing x4</p>	 <p><b>15</b> 60 tube plug x2</p>	 <p><b>16</b> ∅ 48 tube plug x2</p>
 <p><b>17</b> 7560 tube bushing x2</p>	 <p><b>18</b> ∅ 5025 tube bushing x4</p>	 <p><b>19</b> ∅ 38 popper pin x1</p>

# PARTS LIST

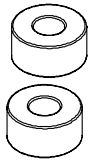

**20** x2  
Rubber  
stopper

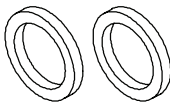

**21** x2

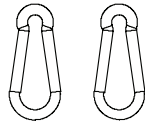

**22** x2  
Carabiner

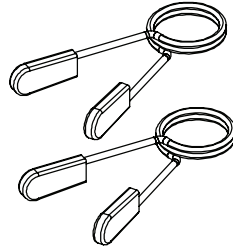

**23** x2

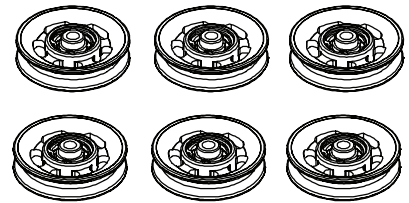

**25** Ø90 pulleys  
x6

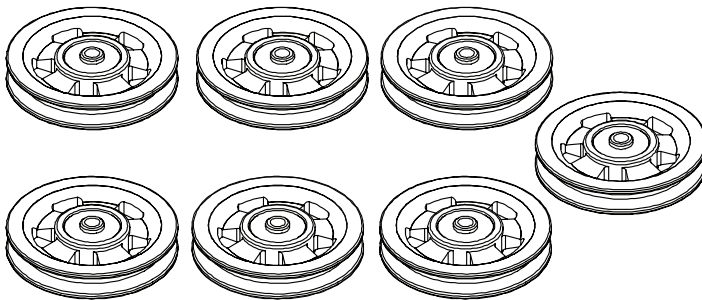

**24** Ø114 pulleys  
x7

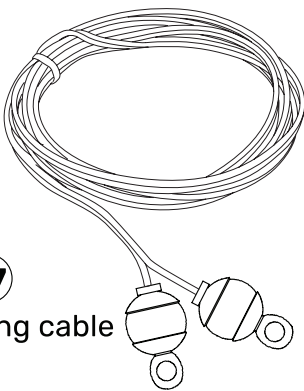

**27**  
Long cable  
x1

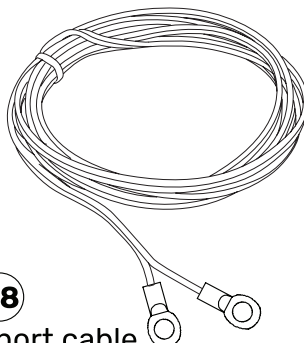

**28**  
Short cable  
x1

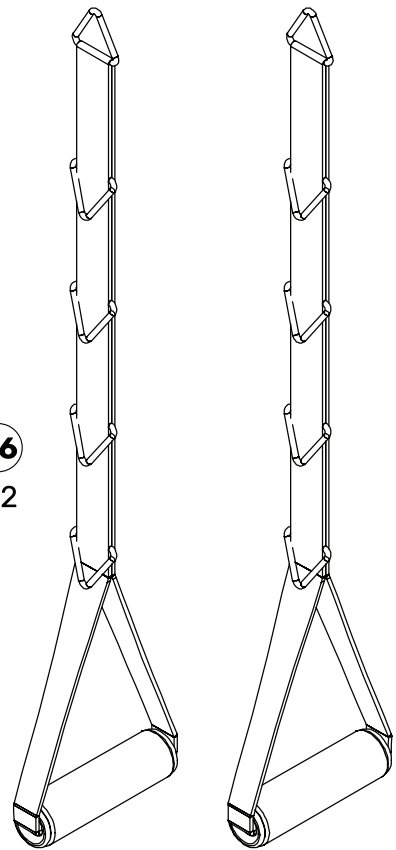

**26**  
x2

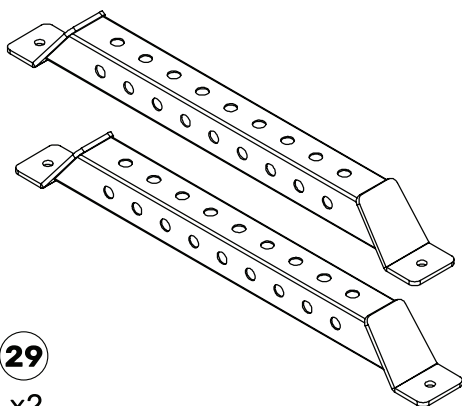

**29**  
x2

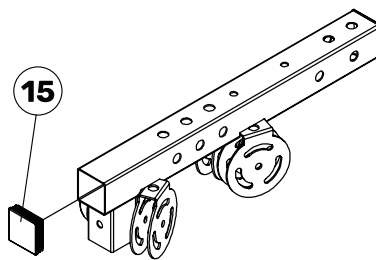

**30**  
x1

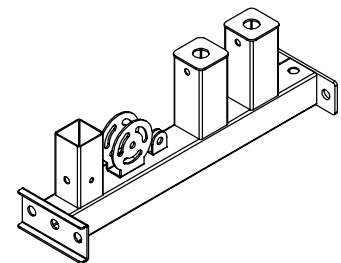

**31**  
x1

# PARTS LIST

**32**

x1

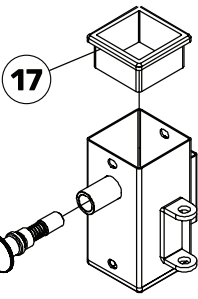

**34**

x1



**37**

x2

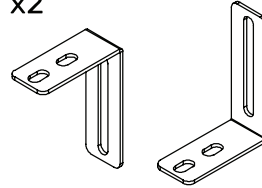

**38**

x2

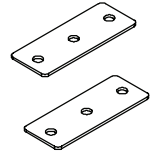

**33**

x1

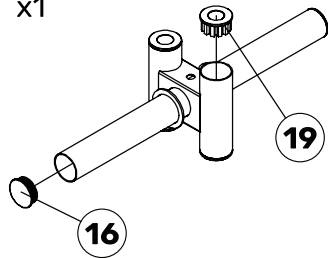

**36**

x1



**35** Swivel pulley housing  
x2

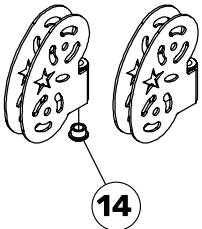

**39**

x1

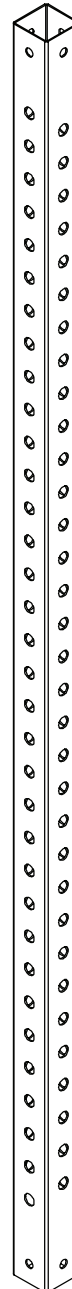

**40**

x2

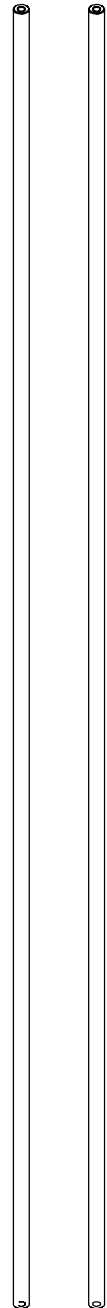

# TOOLS REQUIRED

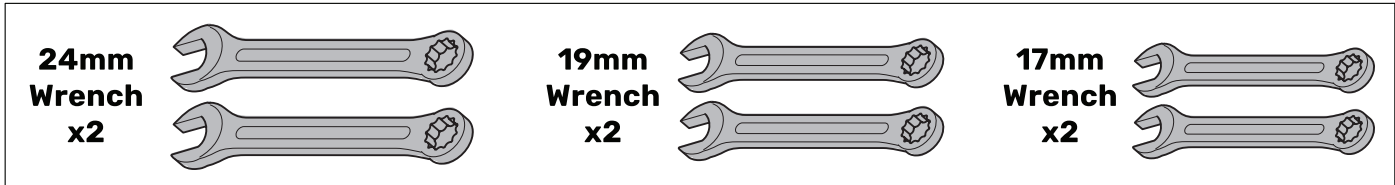

# ASSEMBLY

**PRO TIPS:** For easier assembly, group the hardware together for each step  
 Group the bolts, washers and nuts according to sizes. (M16 bolt, M16 washer, M16 nut).

**1** Assemble the base. Fix (29) to the base with (38) and secure with M16x90 bolt (1), M16 washer (11) and M16 nut (8). Both sides.  
**Note direction.**

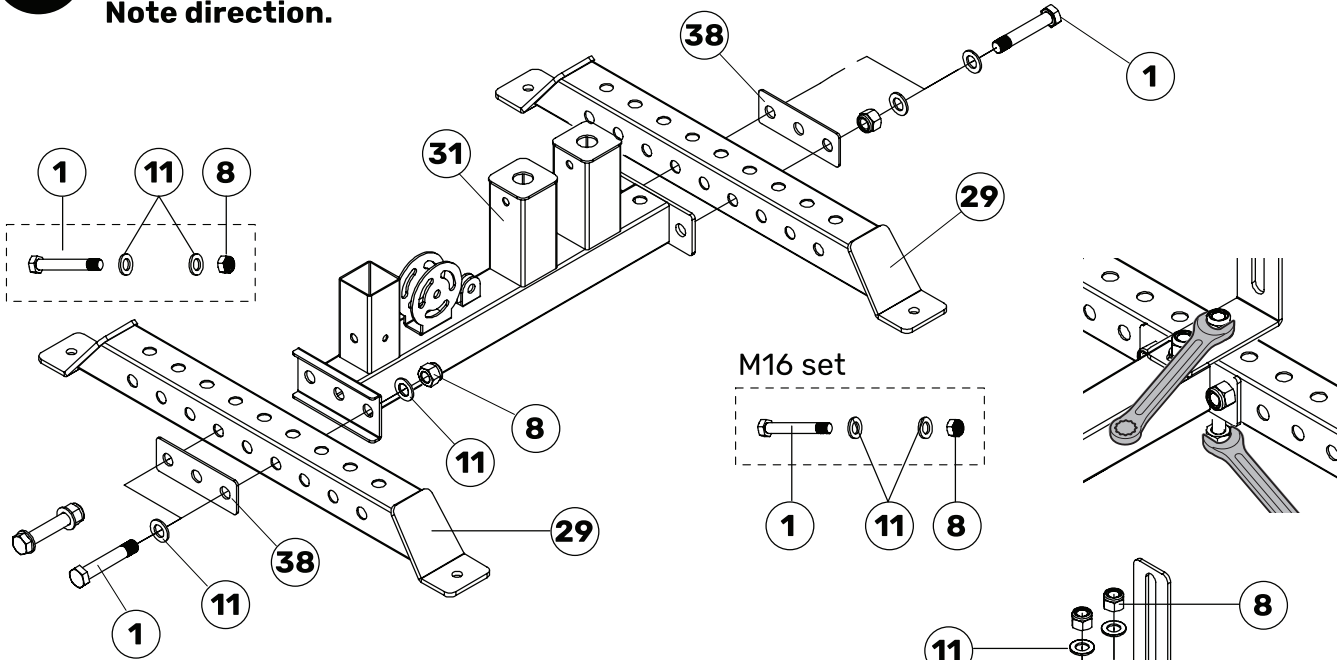

**Pro tip:** Feet holes (29) can bias either direction from the frame (31), to create room for a bench if this is being installed as a squat stand and don't have to be centre.

**2** Attach the end bracket (37) fix with M16 set.  
**Note direction.**

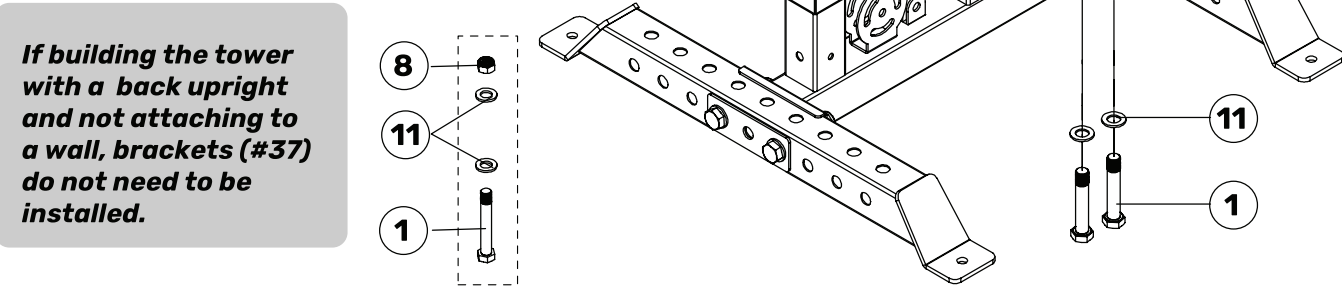

*If building the tower with a back upright and not attaching to a wall, brackets (#37) do not need to be installed.*

**3**

Attach the upright (39). Fix front with M10x70 bolt (4), M10 washer (13) and M10 nut (10). Secure both sides with M10x20 (7) and M10 washer (13).

**4**

Attach (40). Fix with M10x70 bolt (4), M10 washer (13) and M10 nut (10).

**5**

Attach Swivel pulley housing (35) and fix with M12x80 bolt (2), M12 washer (12) and M12 nut (9). **Note direction.**

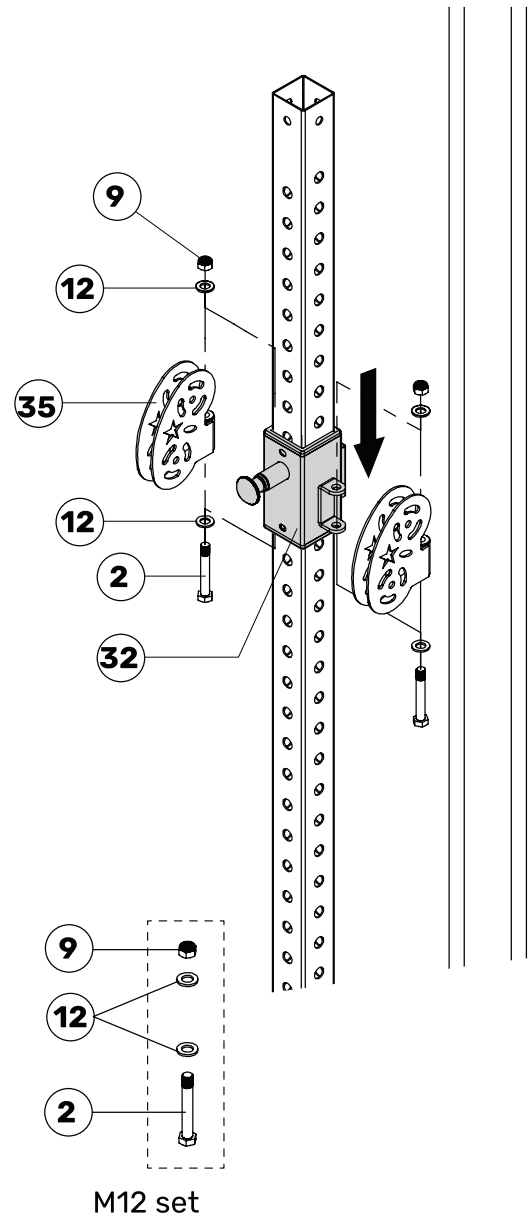
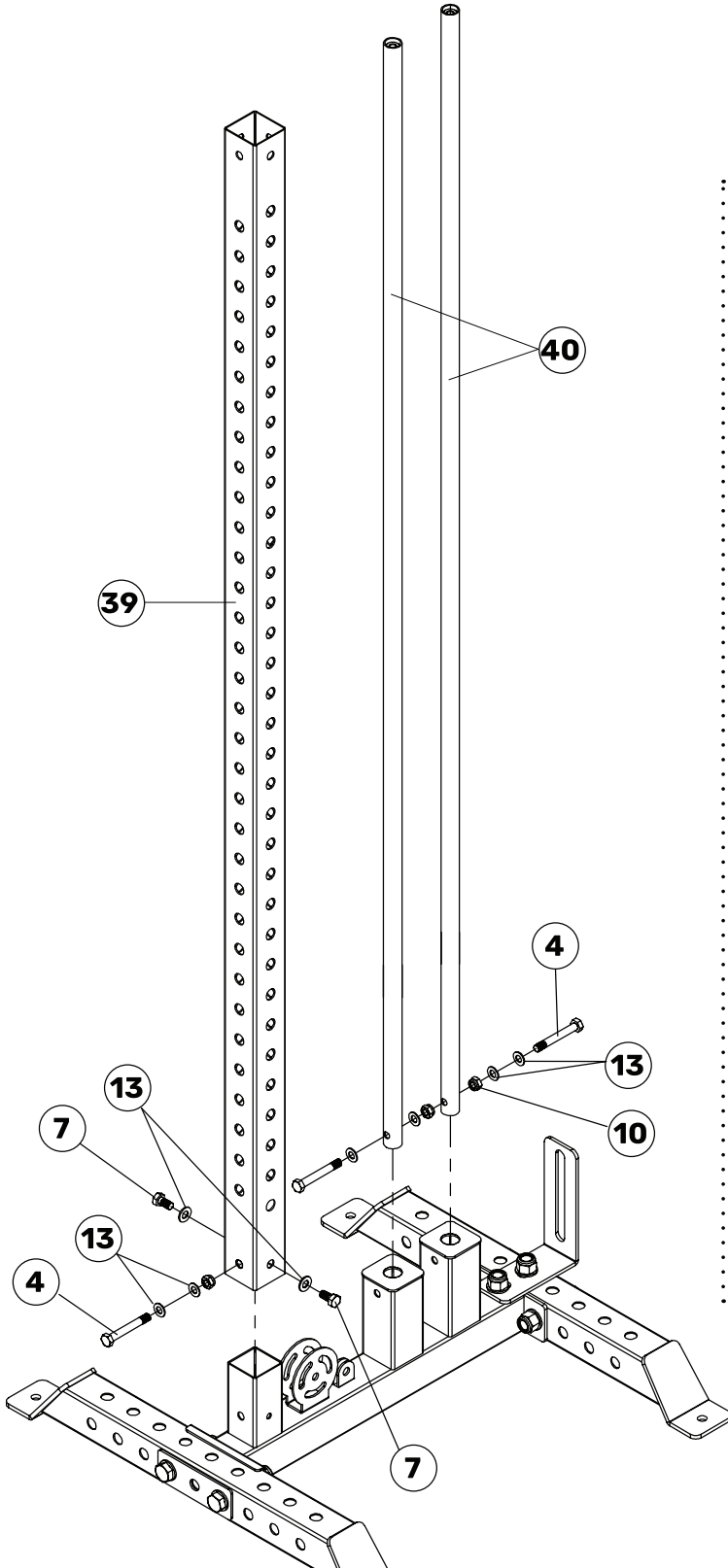

M12 set



**6** Install rubber stopper (20) and plate trolley (33, 21, 23) from top.

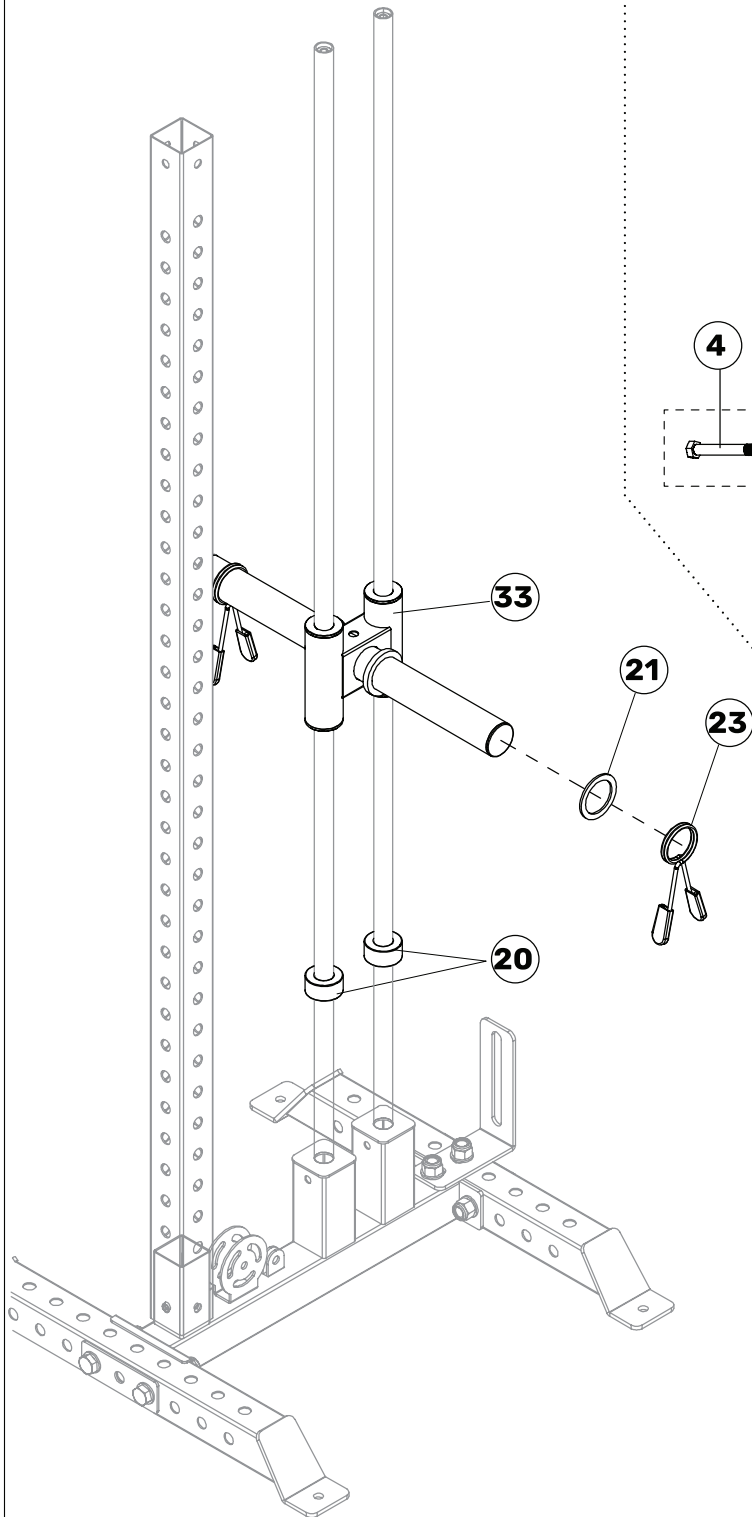

**7** Attach top section (30).  
Fix with M10x75 bolt (3) and M10 washer (13).  
Fix front with M10x70 bolt (4) M10 washer (13) and M10 nut (10).

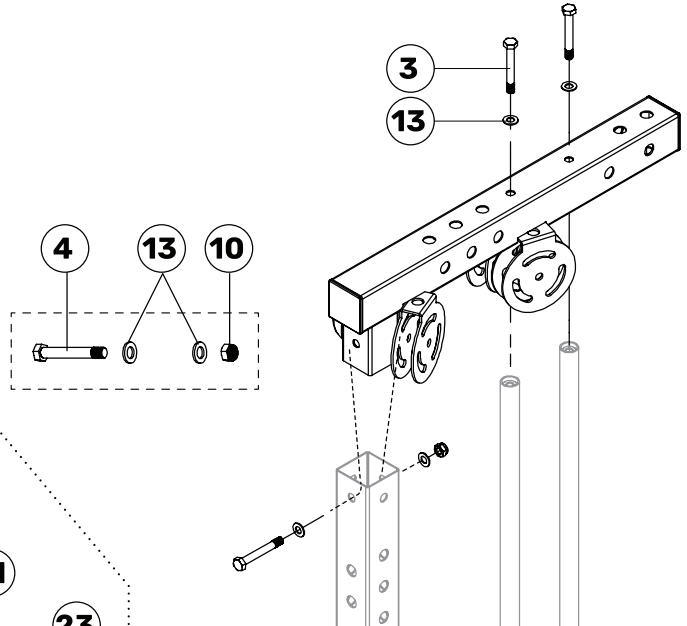

If mounting tower to the wall,  
attach bracket (37).  
Fix with M16x90 bolt (1)  
M16 washer (11) and M16 nut (8).

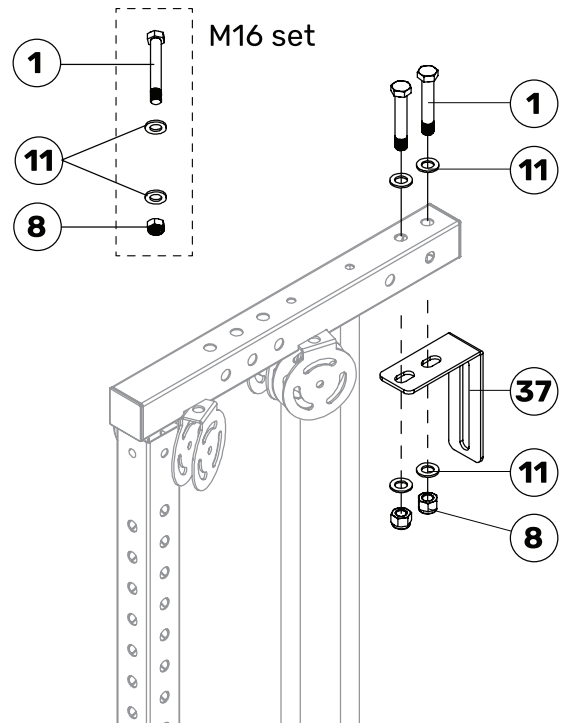

## Right side

**Pro tip:** Make sure to place the cable at the middle of the pulley.

**Reference photo of installed top cable.**

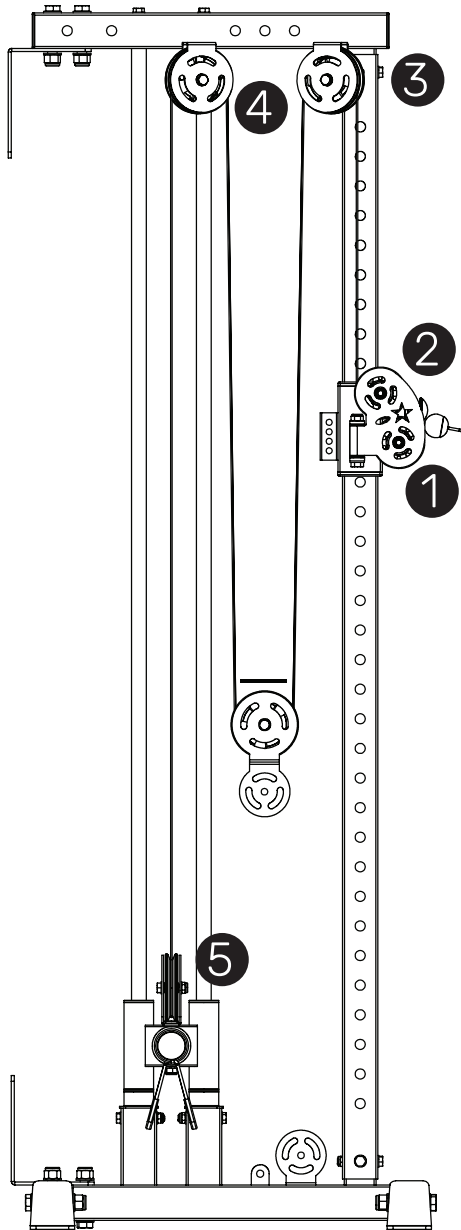

**8**

Attach two small pulleys (25) to height selector (35) fix using M10x45 bolt (5), M10 washer (10) and M10 nut (13).

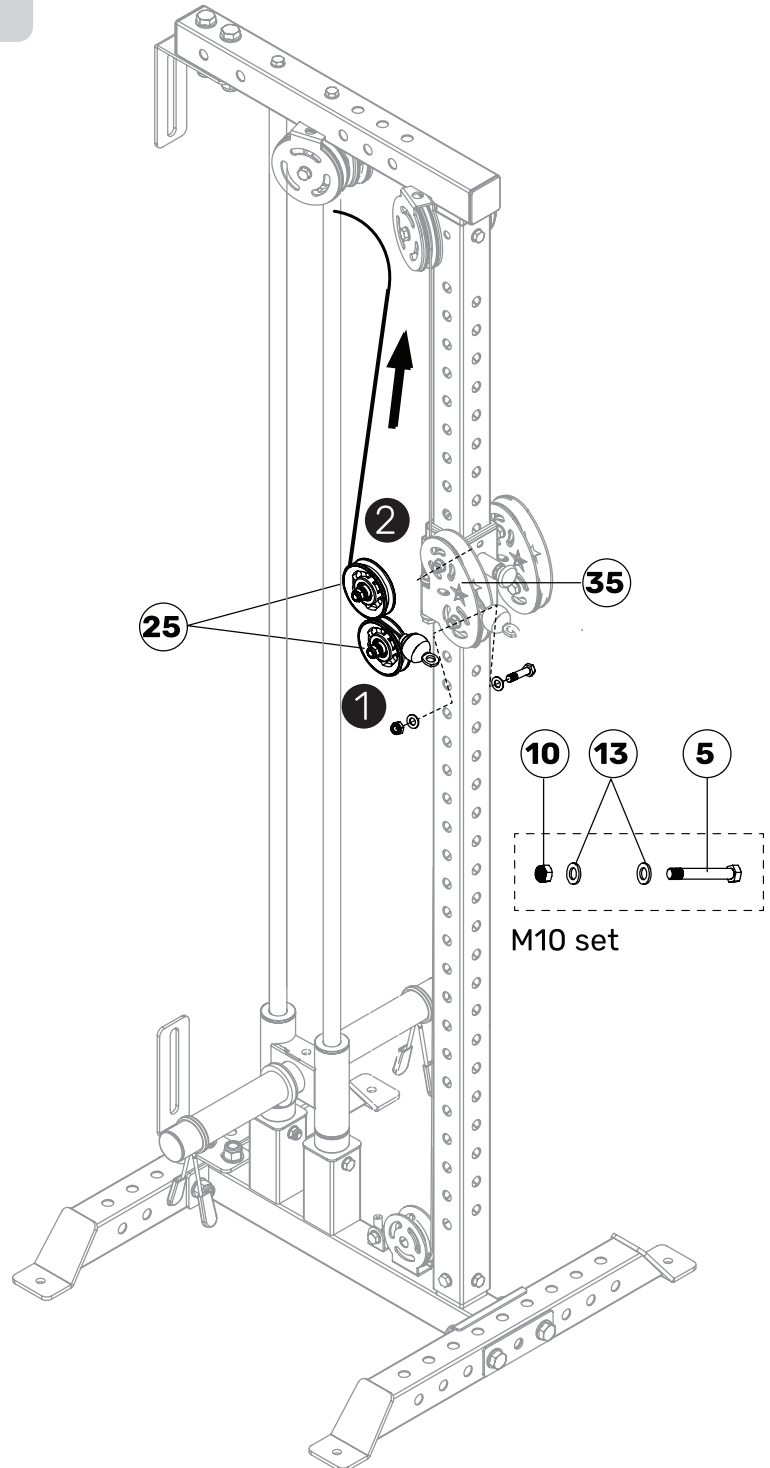

# ASSEMBLY

**9** Attach large pulleys (22) for step 3, 4 fix M10x70 bolt (4), M10 washer (10), M10 nut (13).

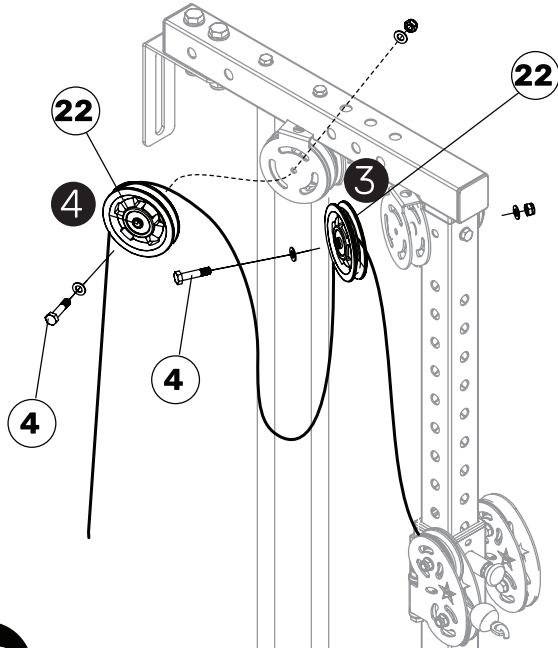

**10** Attach (36) to plate trolley, with an M10 washer (10), M10 nut (13).

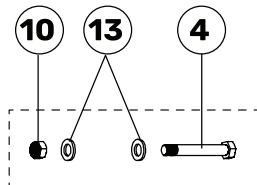
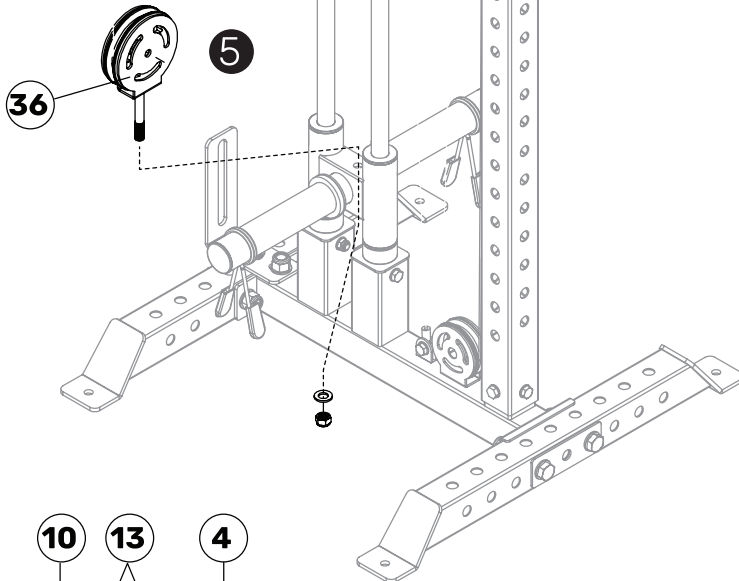

M10 set

**11** Add a large pulley (22) with the cable and fix with M10x70 bolt (4), M10 washer (10), M10 nut (13).

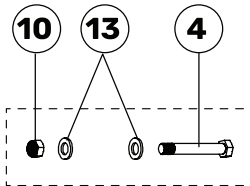
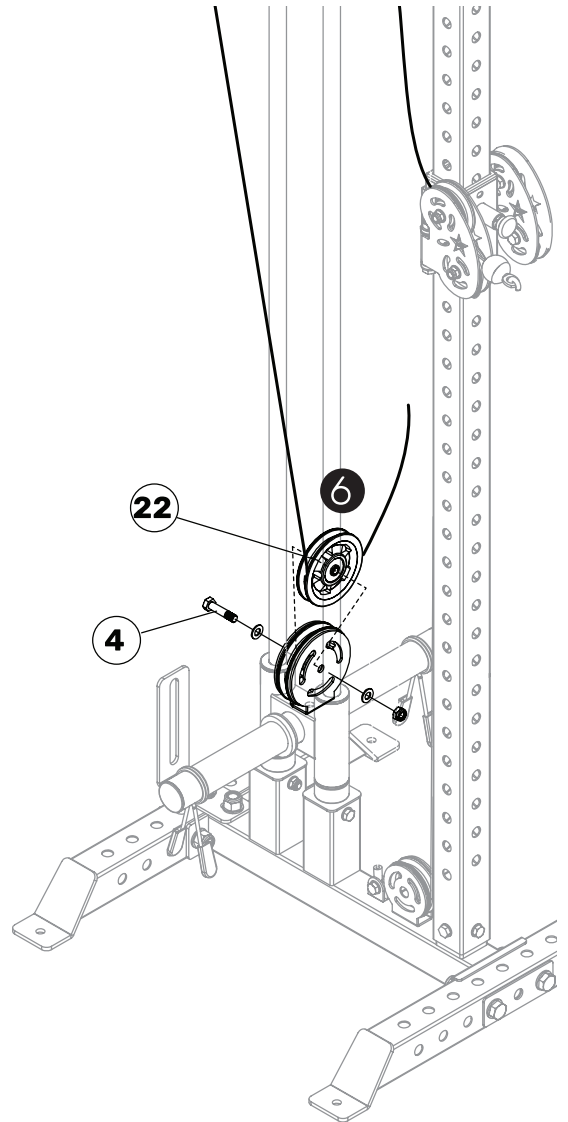

M10 set

## Left side

**Pro tip:** Make sure to place the cable at the middle of the pulley.

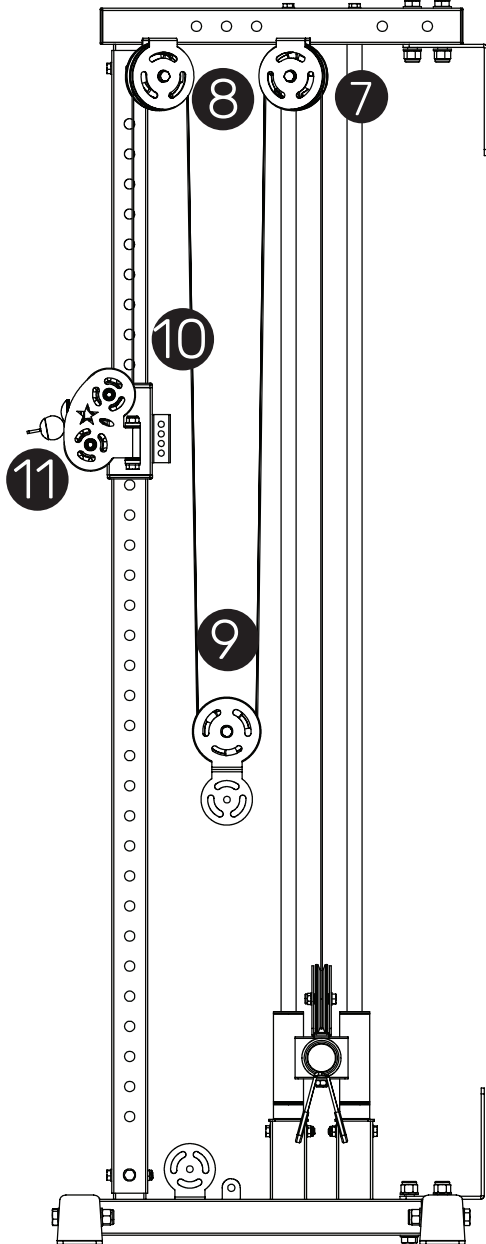

**12** Pull the cable up, then attach another large pulley(22). Fix with M10 set.

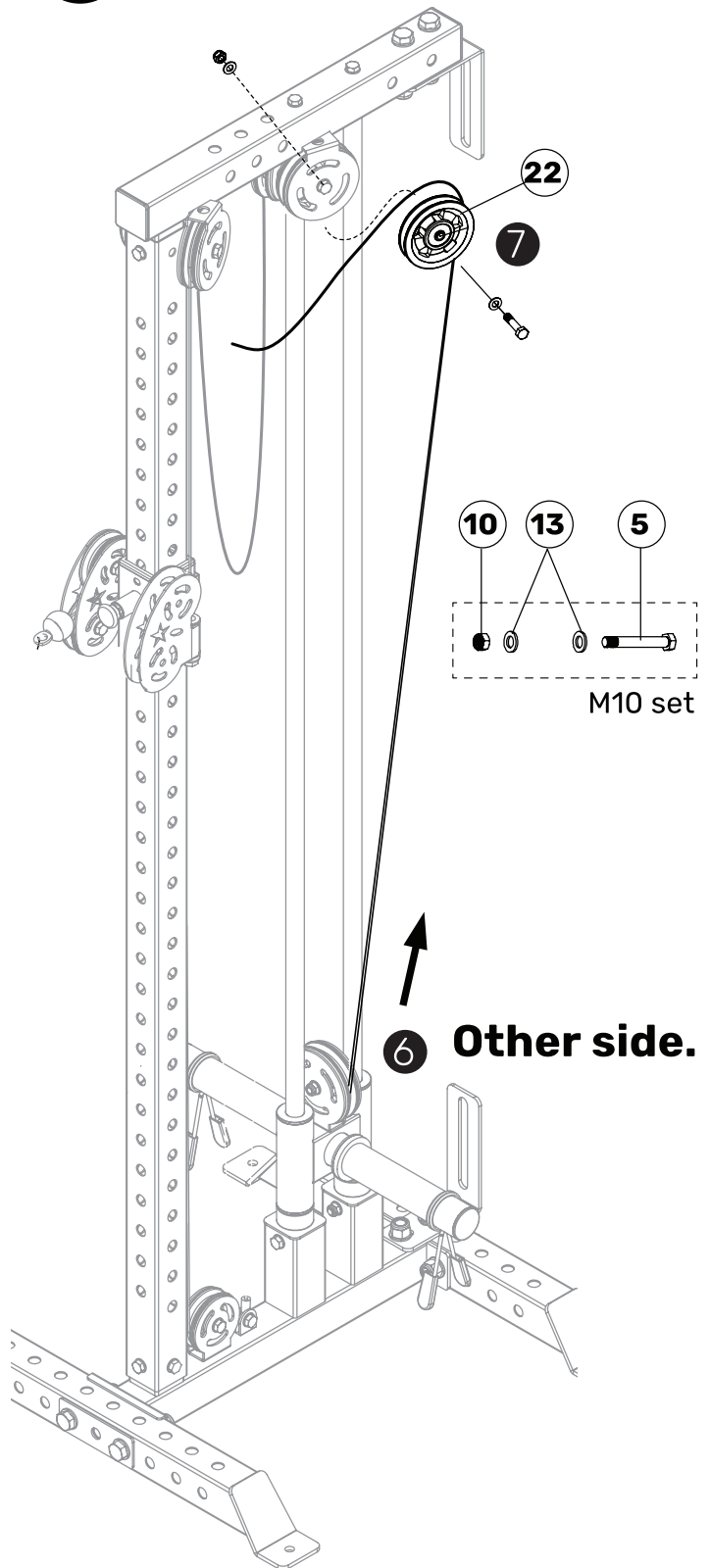

- 13** Attach another large pulley (22).  
Fix with M10 set.

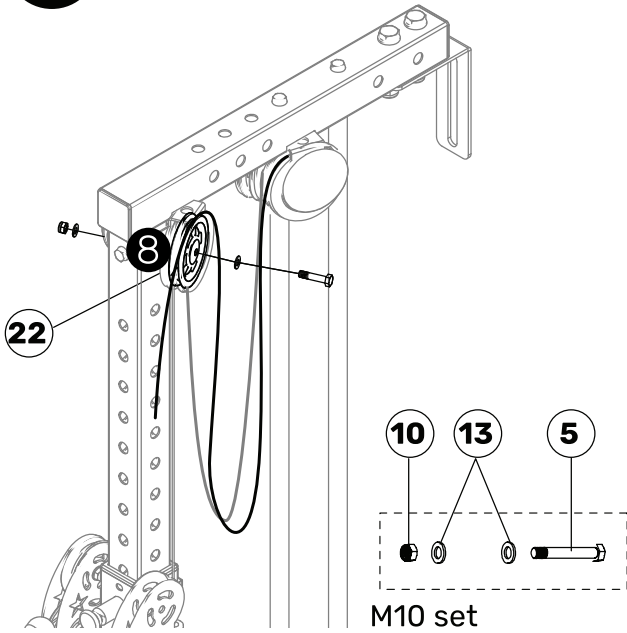

- 14** Center 2 cables on 2 large pulleys (22).  
Fix it on (34), secure with M10 set.

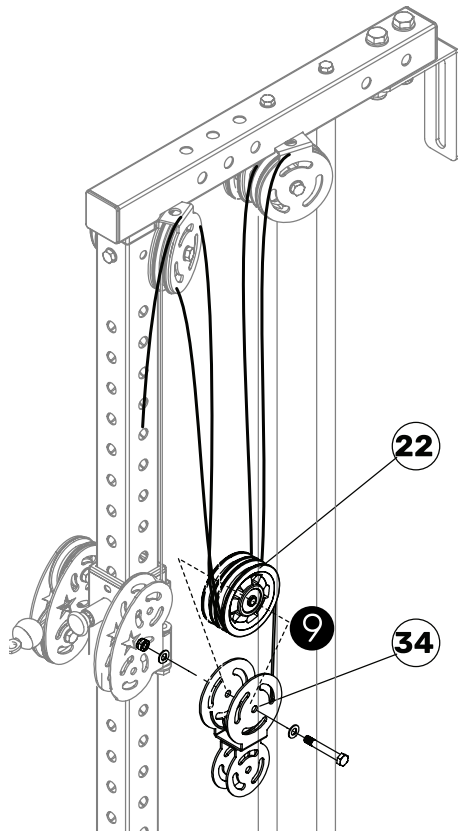

- 15** Attach the last two small pulleys (25)  
to height selector (35) fix using  
M10x45 bolt (5), M10 washer (10)  
and M10 nut (13).

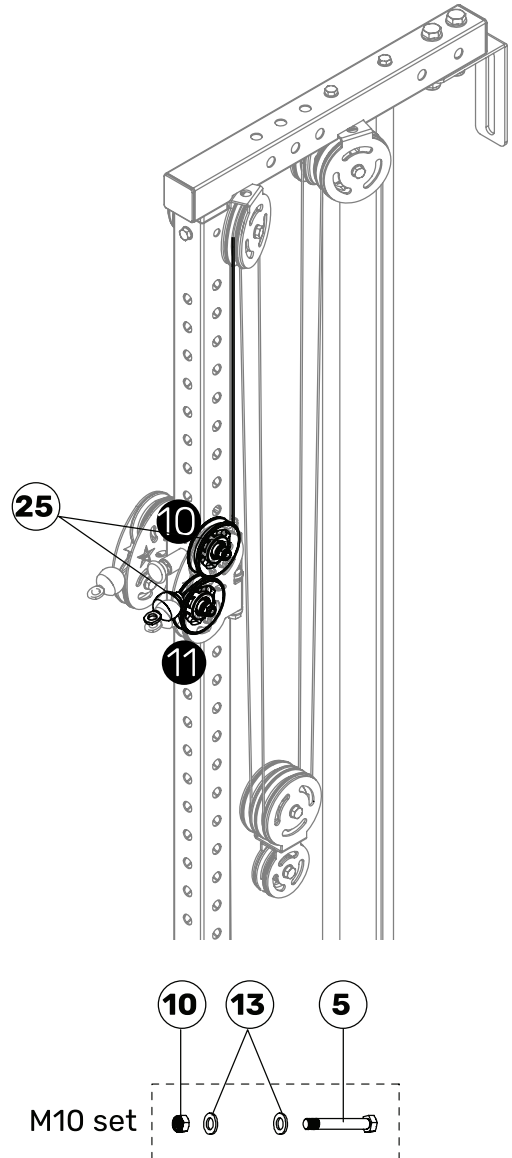

- 16** Attach one end of the cable (28) to the bottom of the base. Fix with M10x70 (4), M10 washer (13) and M10 nut (10).

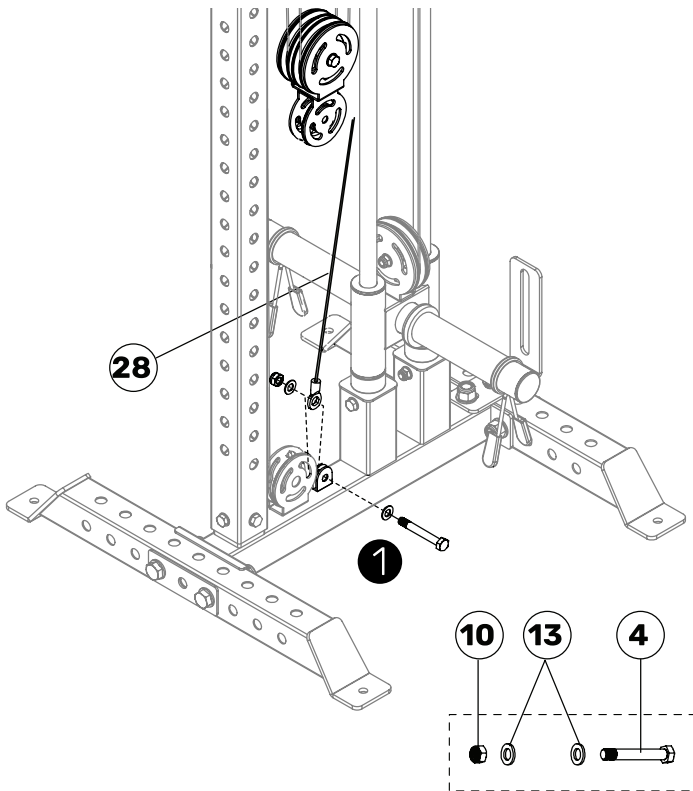

- 17** Pull the cable up to the hanging pulley (25) fix with M10x45 (5), M10 washer (13) and M10 nut (10).

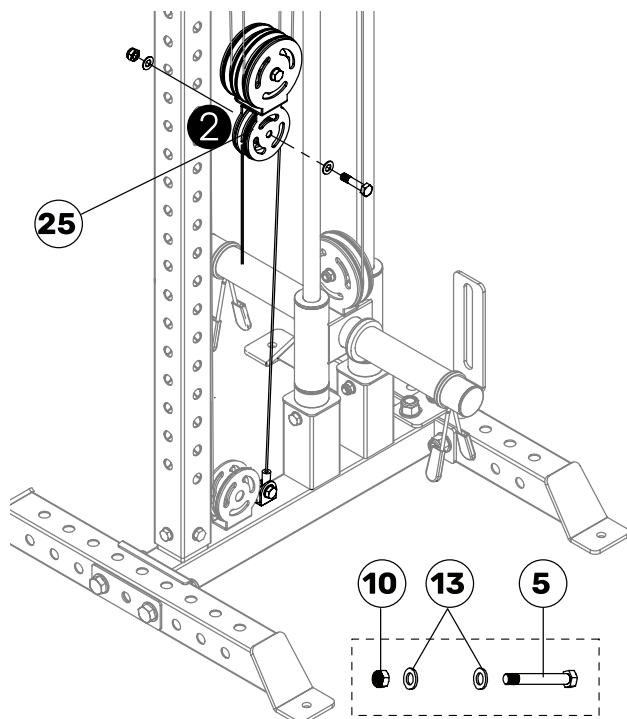

- 18** Pull the cable down and attach pulley (25) fix with M10x45 (5), M10 washer (13) and M10 nut (10).

- 19** Attach the loose end of the cable to the height selector handle (32) fix with M10x45 (5), M10 washer (13) and M10 nut (10).

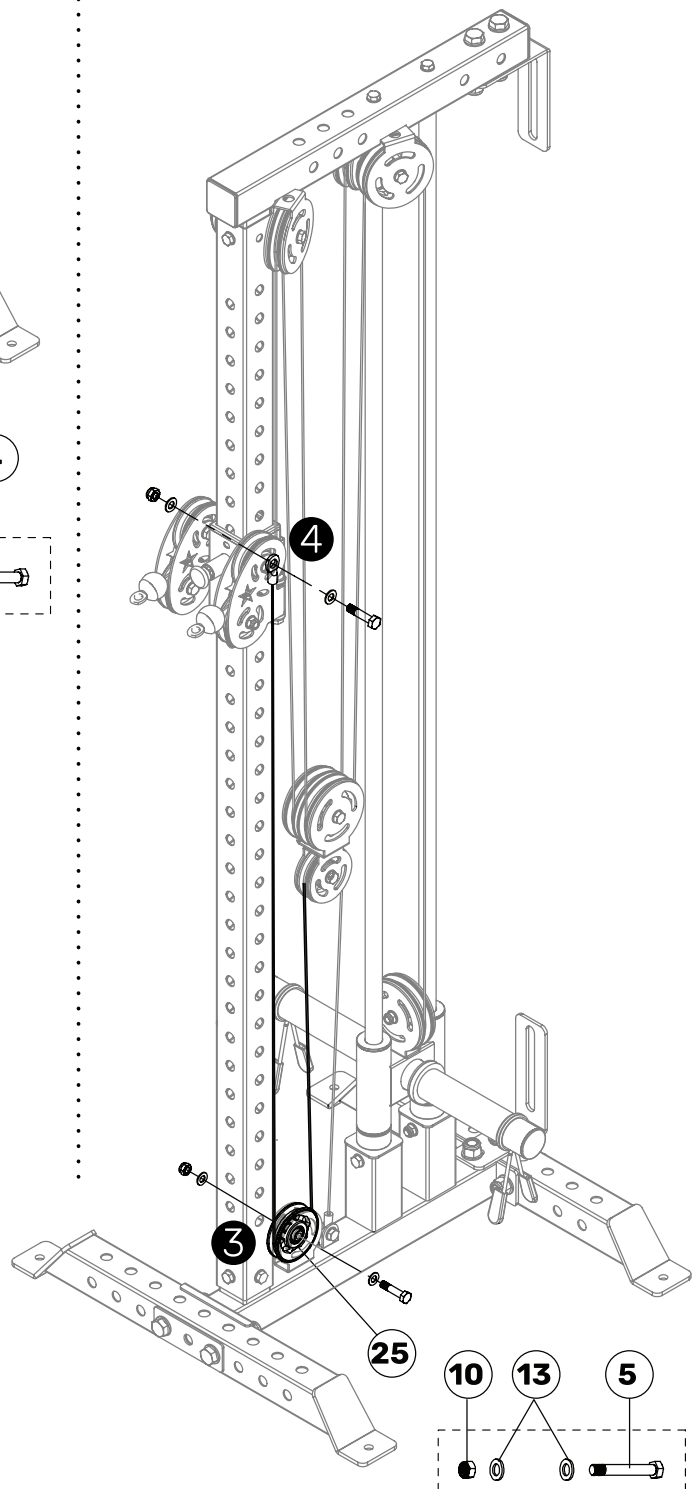

**20**

Attach carabiner (22) at the end of the cable and add the handle assembly (26).

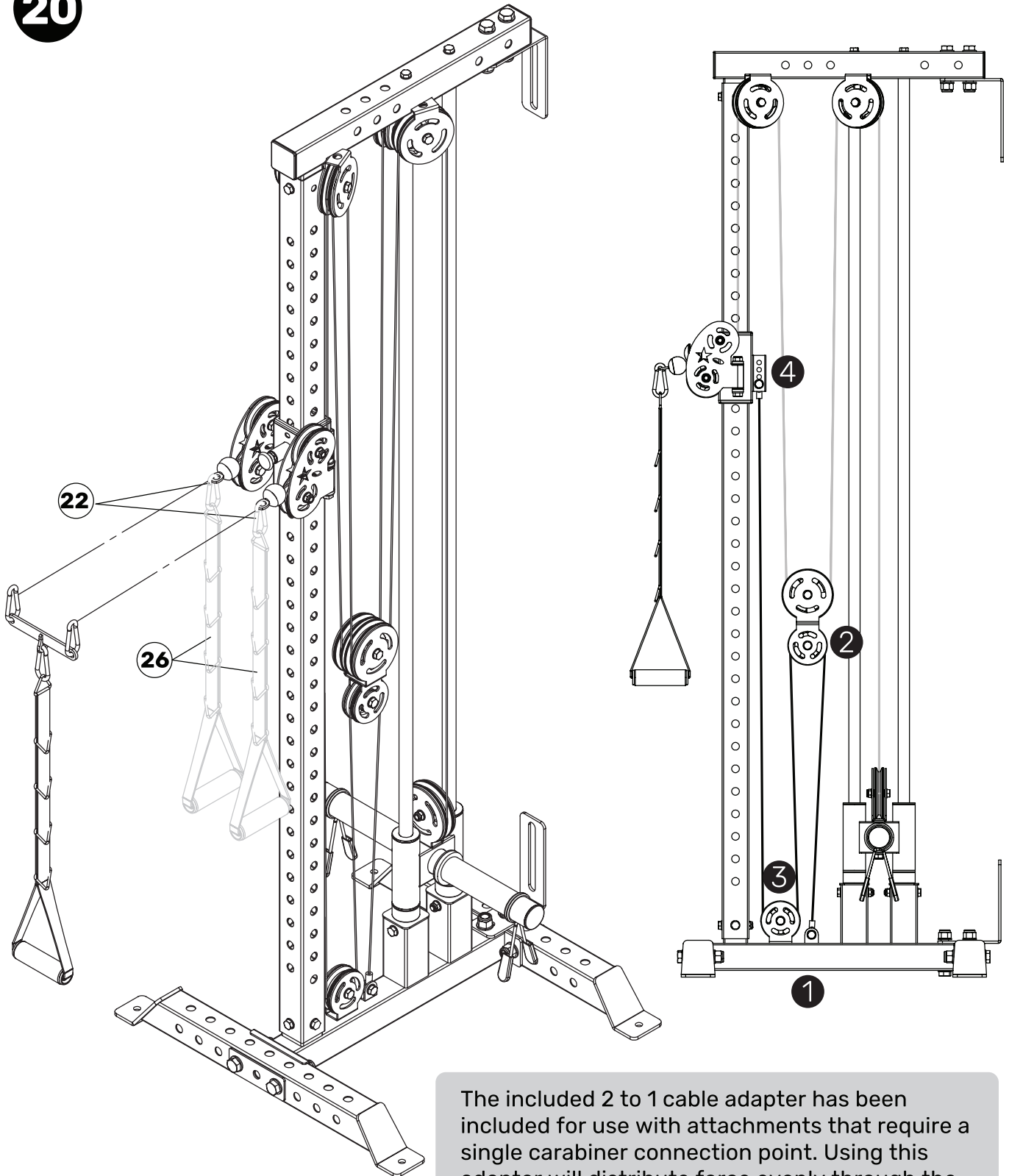

The included 2 to 1 cable adapter has been included for use with attachments that require a single carabiner connection point. Using this adapter will distribute force evenly through the cables, preventing long-term issues like twisting and damage.

# YOU'RE FINISHED!

**WANT TO LEARN MORE ABOUT THE PLATE LOADED CABLE TOWER? CHECK OUT THE OVERVIEW VIDEO:**



## VISIT OUR SHOWROOMS



Calgary - HQ



Toronto - Showroom



Indianapolis - Showroom

Corporate Headquarters 7880 66 St SE, Calgary, AB, Canada

U.S.A. Headquarters 5925 W 71st St, Indianapolis, IN, U.S.A.

Toronto Store 39 Haist Ave # 2, Woodbridge, ON, Canada

[support@bellssofsteel.com](mailto:support@bellssofsteel.com) | 1-888-718-7997