

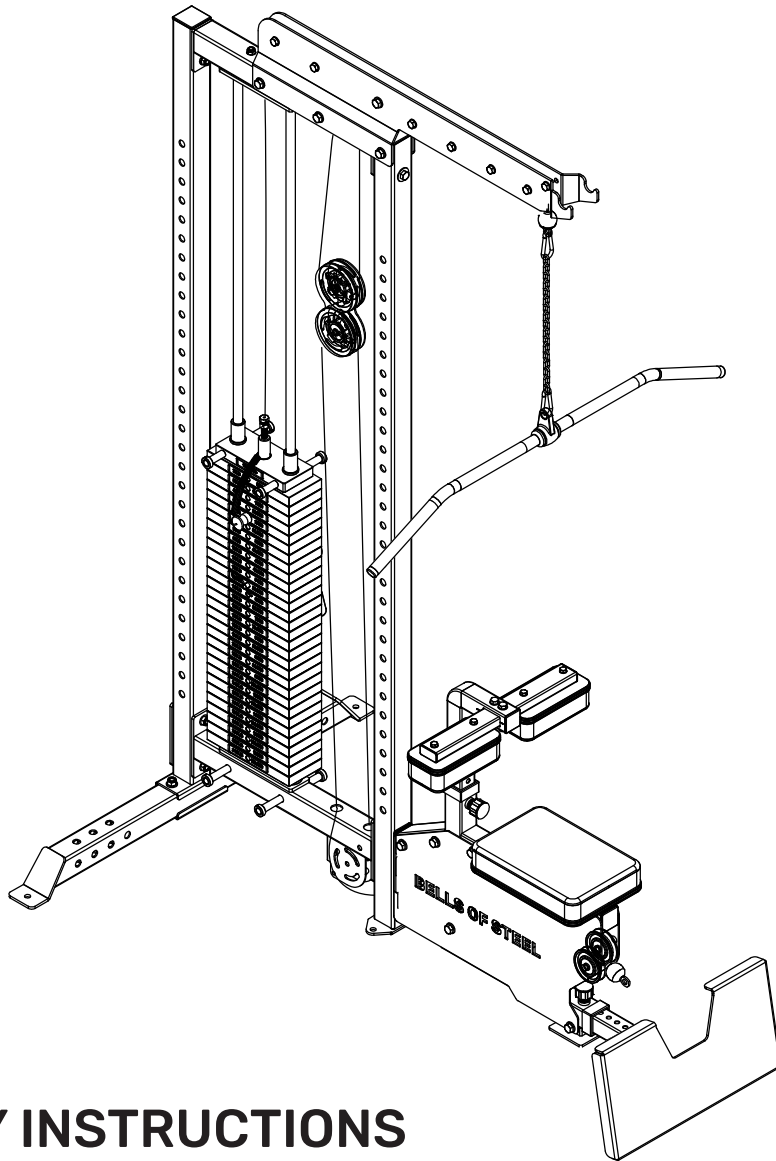

LAT TOWER 310LB

SKU: LAT-MA

PO:



ASSEMBLY INSTRUCTIONS

   **BELLSOFSTEEL**

Stuck? Scan the QR code for the assembly video

www.bellssofsteel.com | www.bellssofsteel.us | Telephone: 1-888-718-7997



BUILDING STRENGTH, ONE BOLT AT A TIME.



Welcome to Bells of Steel, you've made an excellent choice.

First off I want to say thank you for supporting my small business.

I've put significant thought into designing this product to enhance your lifting experience and help you reach your full potential. I hope you love it!

I've done my best to keep the setup of your new gear simple. If you find yourself needing a bit more assistance than the included instructions, check our youtube page for assembly videos or feel free to email us for troubleshooting guidance.

Kaevon Khoozani



Crush your Gains! Subscribe to our YouTube for workouts & how-to's.

@BELLSOFSTEEL



Warranty & returns? We got you covered—check here:

bellssofsteel.com/pages/warranty

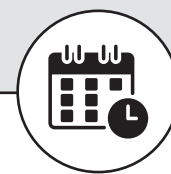

Changed your mind? No sweat. 30-day refund guarantee:

bellssofsteel.com/policies/refund-policy



Let us know how we've done

Love it? Leave a review! Hate it? We still read it. Help us get better by reviewing our products.



Customer Notice

If you are missing any parts, or otherwise have any warranty issues/shipping damages, please file a warranty claim on our website.

Before discarding the box, please take clear photos of the box and shipping labels, as these may be required if parts are missing or the item is damaged.



BELLSOFSTEEL | www.bellssofsteel.com | www.bellssofsteel.us

BEFORE WE BEGIN, LET'S STAY SAFE.



A GUIDE TO SAFETY

We know you are excited to use your new Bells of Steel gear, but please read through this Guide to Safety to ensure you do not hurt yourself or others while exercising. It is your responsibility to ensure that all users of the equipment are informed of all warnings and instructions in this manual. TO REDUCE THE RISK OF SERIOUS INJURY, READ THE FOLLOWING IMPORTANT PRECAUTIONS BEFORE USING YOUR BELLS OF STEEL PRODUCT.

- ① Before starting any exercise program consult your physician. Be aware of your body's signals. Incorrect or excessive exercise can be damaging to your health. STOP EXERCISING IF YOU EXPERIENCE ANY OF THE FOLLOWING SYMPTOMS: PAIN, TIGHTNESS IN YOUR CHEST, IRREGULAR HEARTBEAT, SHORTNESS OF BREATH, LIGHTHEADEDNESS, DIZZINESS, OR FEELINGS OF NAUSEA. IF YOU EXPERIENCE ANY OF THESE SYMPTOMS, STOP EXERCISING IMMEDIATELY AND CONSULT YOUR PHYSICIAN BEFORE CONTINUING WITH YOUR EXERCISE PROGRAM.
- ② It is your responsibility to ensure there is enough space around the product for the intended exercise. Use the product on a flat surface and ensure at least 2 feet (60 cm) of free space around it.
- ③ Children and pets must not be let on or near the product. Moving parts and heavy features of the product can be dangerous and cause serious injury.
- ④ Read all instructions in this manual before using the product and use the product only as described in this manual.
- ⑤ It is your responsibility to ensure that all users of the product are adequately informed of all precautions, have read and understand all warnings, and are informed how to use the product properly.
- ⑥ Keep hands and feet from moving parts. Do not lean or rest on the product.
- ⑦ Wear athletic shoes for foot protection while exercising.
- ⑧ Your product is intended for use in cool, dry conditions. You should avoid storage in extreme cold, hot, or damp areas.
- ⑨ This product is designed for indoor use only.
- ⑩ Ensure that any weight pins that may be included with your product are completely inserted into an appropriate weight plate.
- ⑪ Ensure that any handles that may be included with your product are attached securely before using the product.
- ⑫ Ensure that any nuts and bolts that may be included with your product are securely tightened before use. Regularly re-tighten nuts and bolts.
- ⑬ Ensure any cables that may be included with your product always remain attached to their proper pulleys. If a cable bind occurs during exercise, stop immediately and inspect the part to ensure any interference is fixed.
- ⑭ Do not overexert yourself during any exercise program. Operate the product as intended.
- ⑮ The product should be anchored where required or whenever possible. The product should be secured when not in use.
- ⑯ The product is very heavy. Improper use or assembly can lead to serious injury or death.
- ⑰ SAVE AND REVIEW THESE INSTRUCTIONS.

NOW...

LET THE GAINZ BEGIN

PARTS LIST

Hardware Package

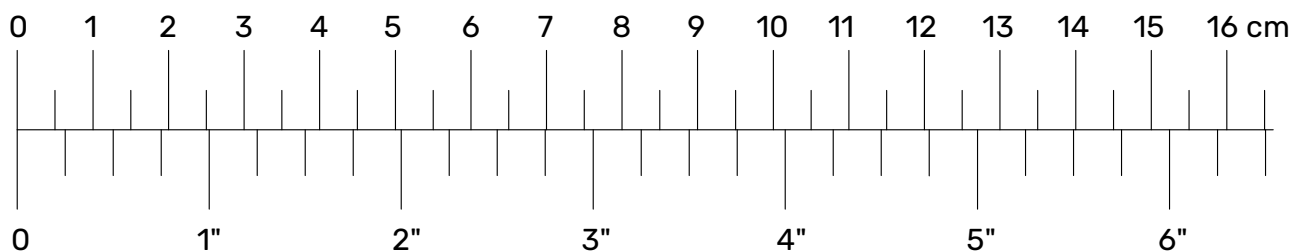
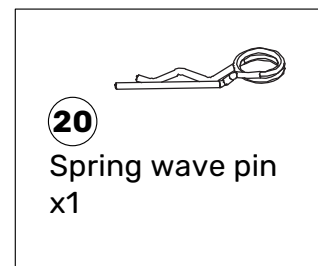
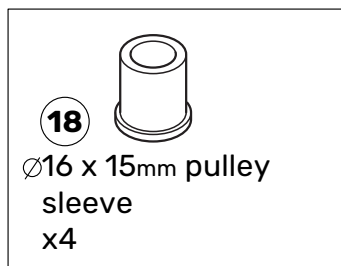
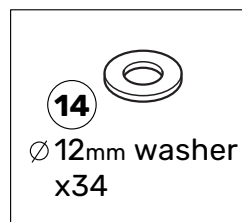
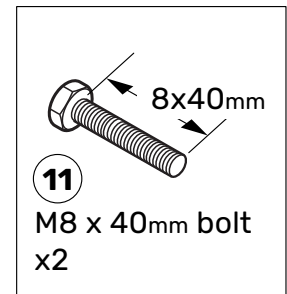
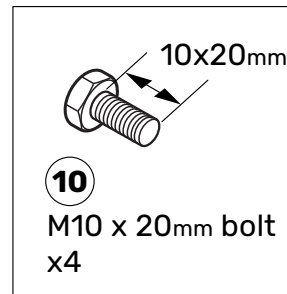
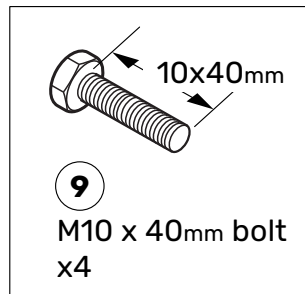
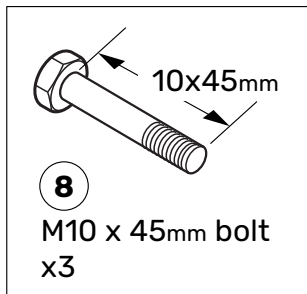
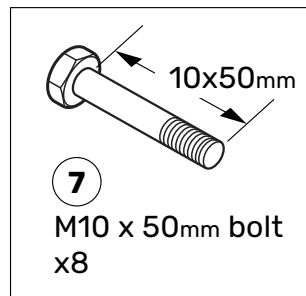
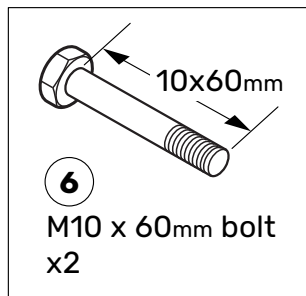
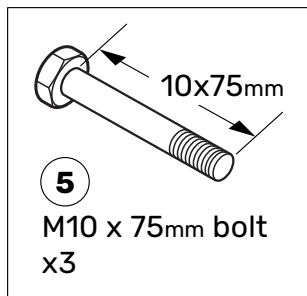
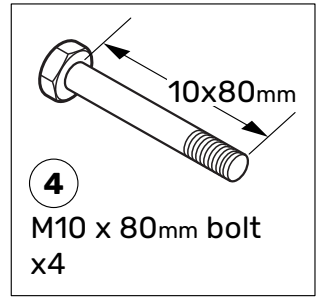
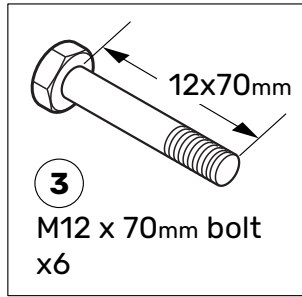
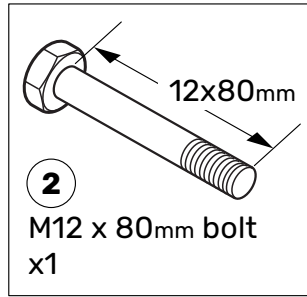
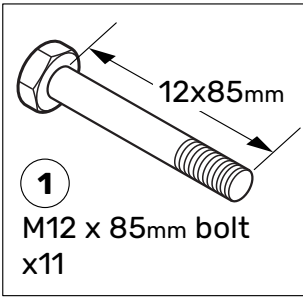

PARTS LIST

Preassembled

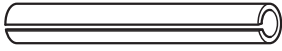

19

Ø12 x 80mm elastic
cylindrical pin
x1

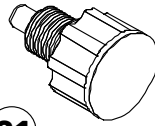

21

M16 popper
x3

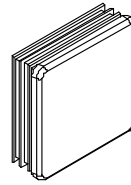

22

60mm tube plug
x2

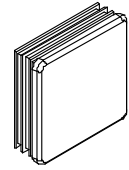

23

50mm tube plug
x1

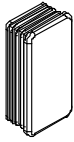

24

2550 tube plug
x4

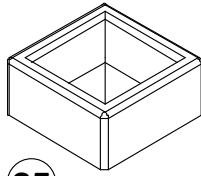

25

5045mm tube bushing
x2



26

50mm tube plug
x1

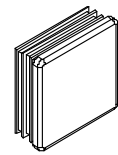

27

44mm tube plug
x1

PARTS LIST

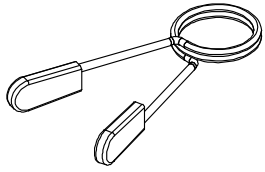

28 x1

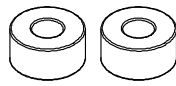

29 x2

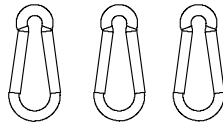

30 Carabiners
x3

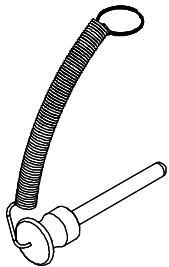

31 x1 Weight selector



32 $\varnothing 80$ pulleys
x2

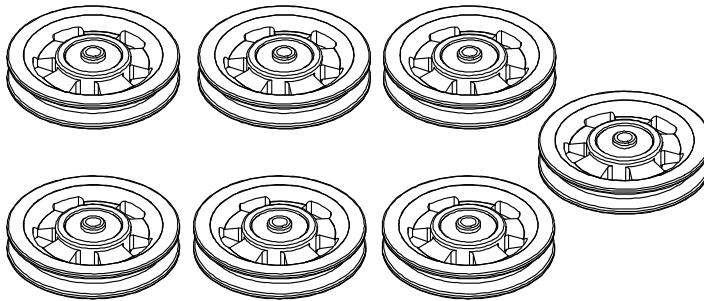

33 $\varnothing 114$ pulleys
x2

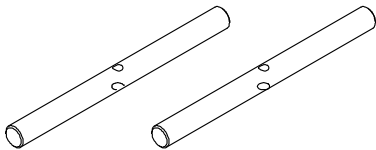

34 x2

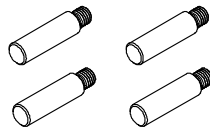

35 x4

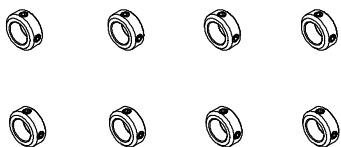

36 x8

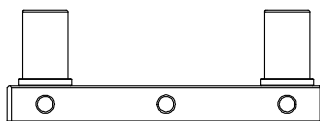

37 x1

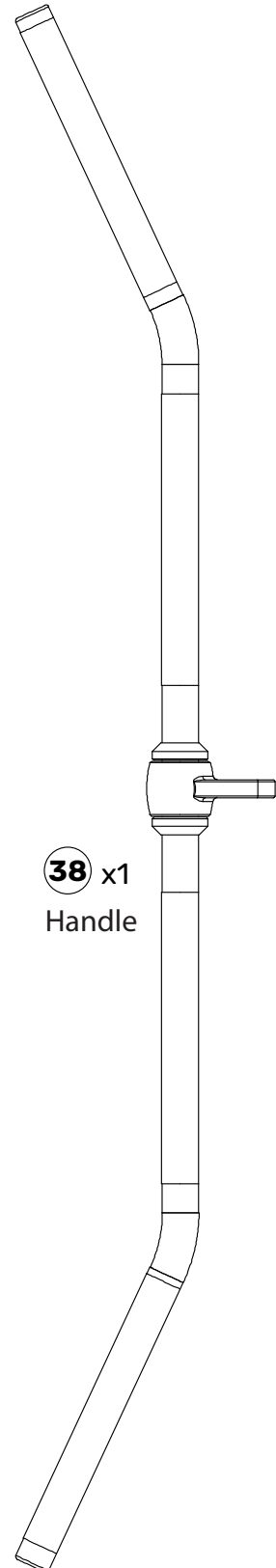

38 x1
Handle

PARTS LIST

10LBS	○	4.5KG
20LBS	○	9.10KG
30LBS	○	13.6KG
40LBS	○	18.2KG
50LBS	○	22.7KG
60LBS	○	27.0KG
70LBS	○	31.8KG
80LBS	○	36.4KG
90LBS	○	40.9KG
100LBS	○	45.5KG
110LBS	○	50.5KG
120LBS	○	54.5KG
130LBS	○	59.1KG
140LBS	○	63.6KG
150LBS	○	68.2KG
160LBS	○	72.7KG
170LBS	○	77.3KG
180LBS	○	81.8KG
190LBS	○	86.4KG
200LBS	○	90.9KG
210LBS	○	95.5KG
220LBS	○	100KG
230LBS	○	104.5KG
240LBS	○	109.1KG
250LBS	○	113.6KG
260LBS	○	118.2KG
270LBS	○	122.7KG
280LBS	○	127.3KG
290LBS	○	131.8KG
300LBS	○	136.4KG

39 Weight stack and stickers
x30

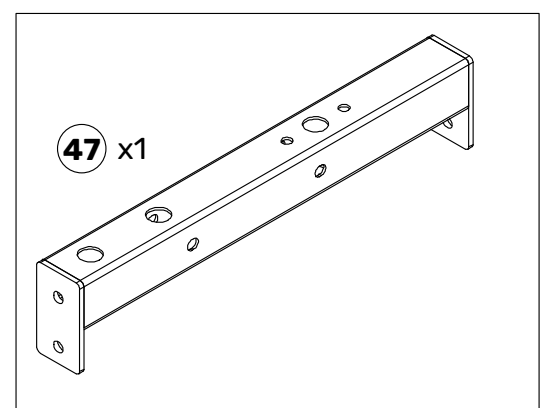
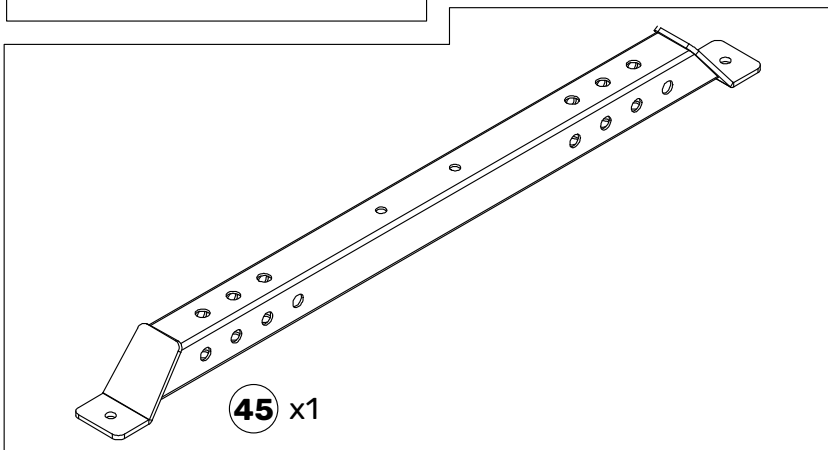
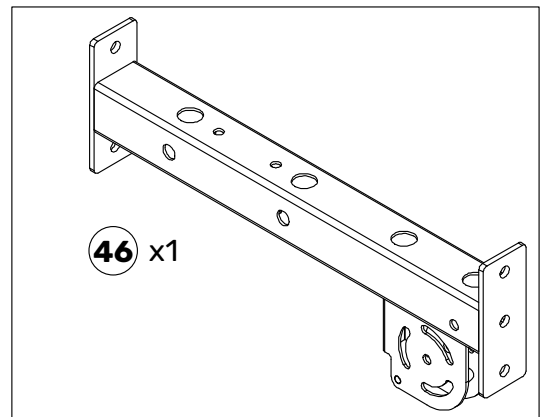
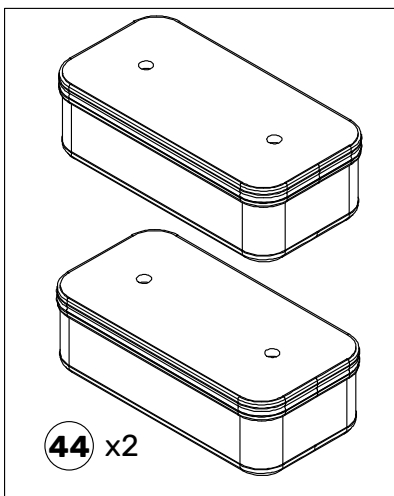
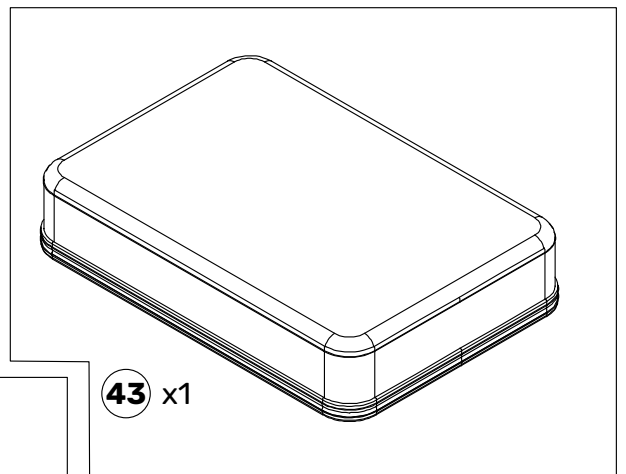
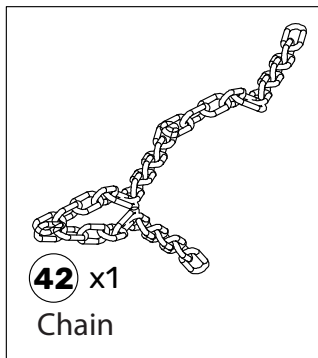
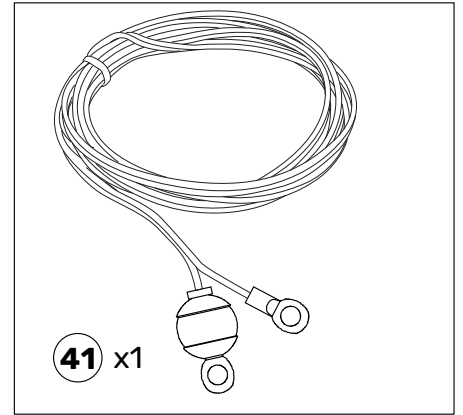
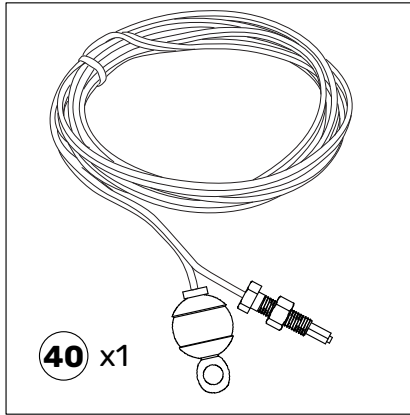

PARTS LIST

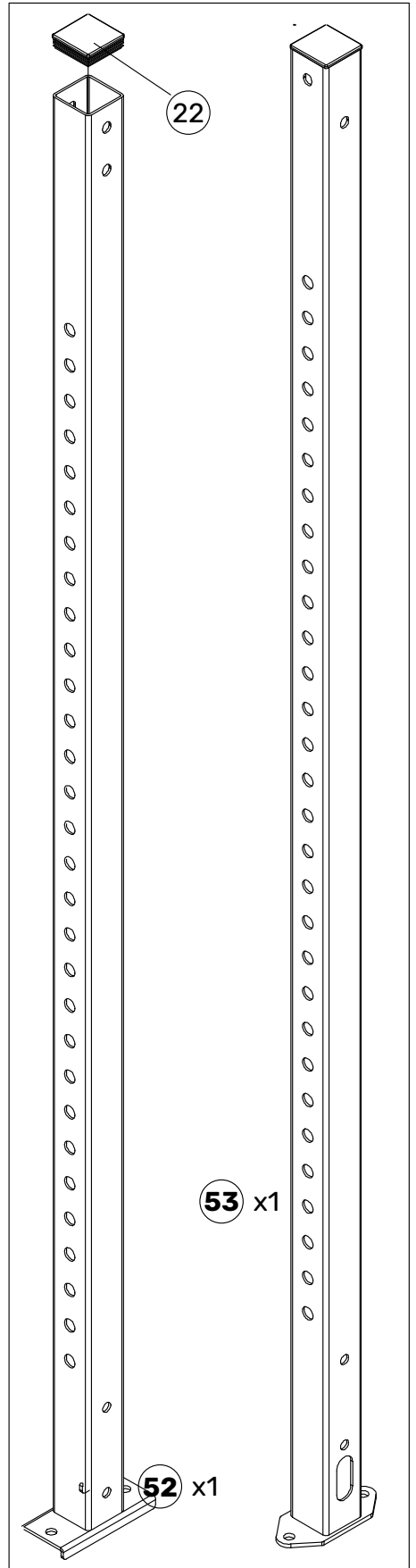
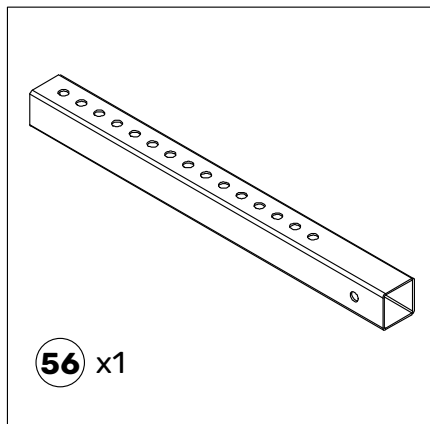
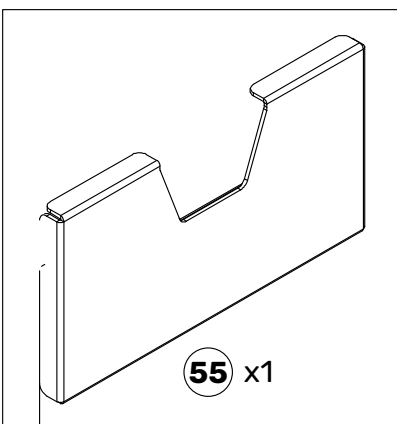
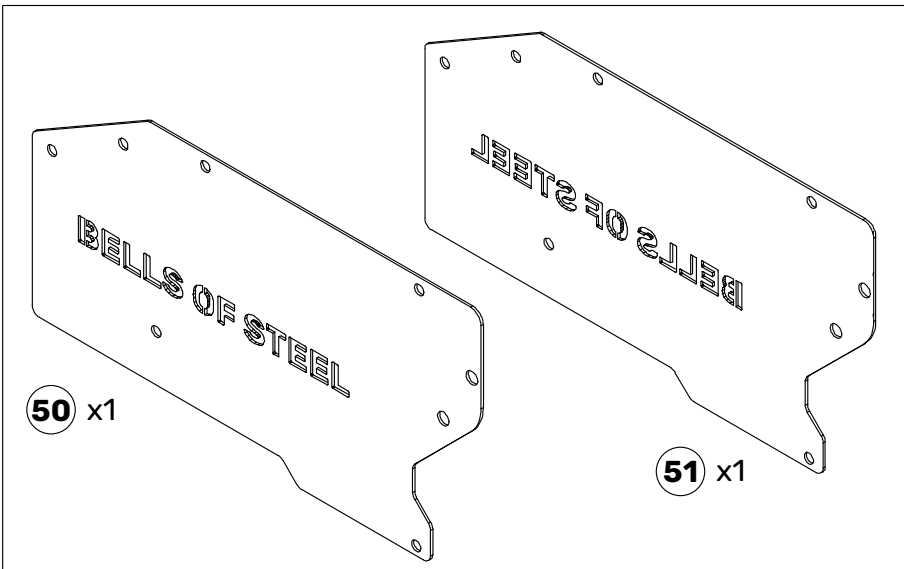
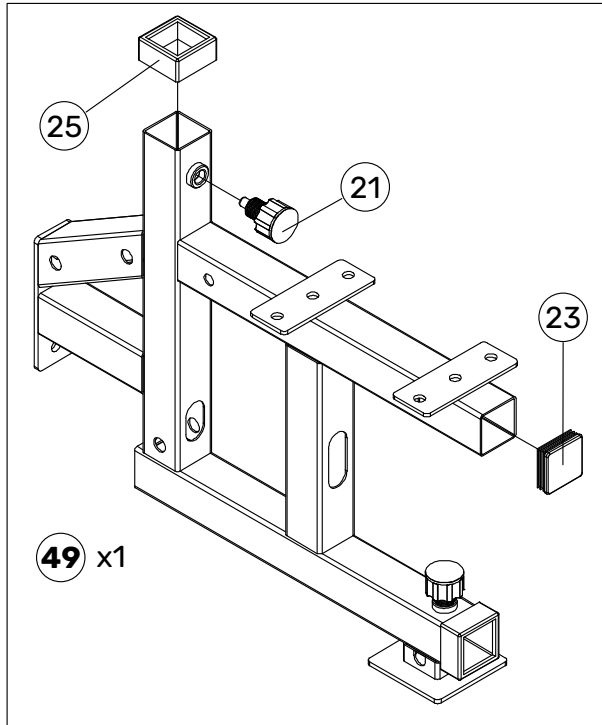
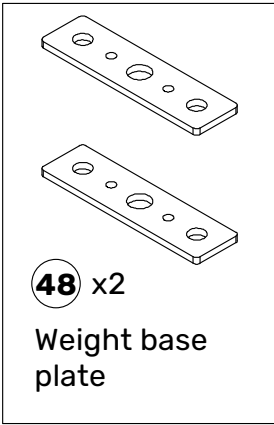

PARTS LIST

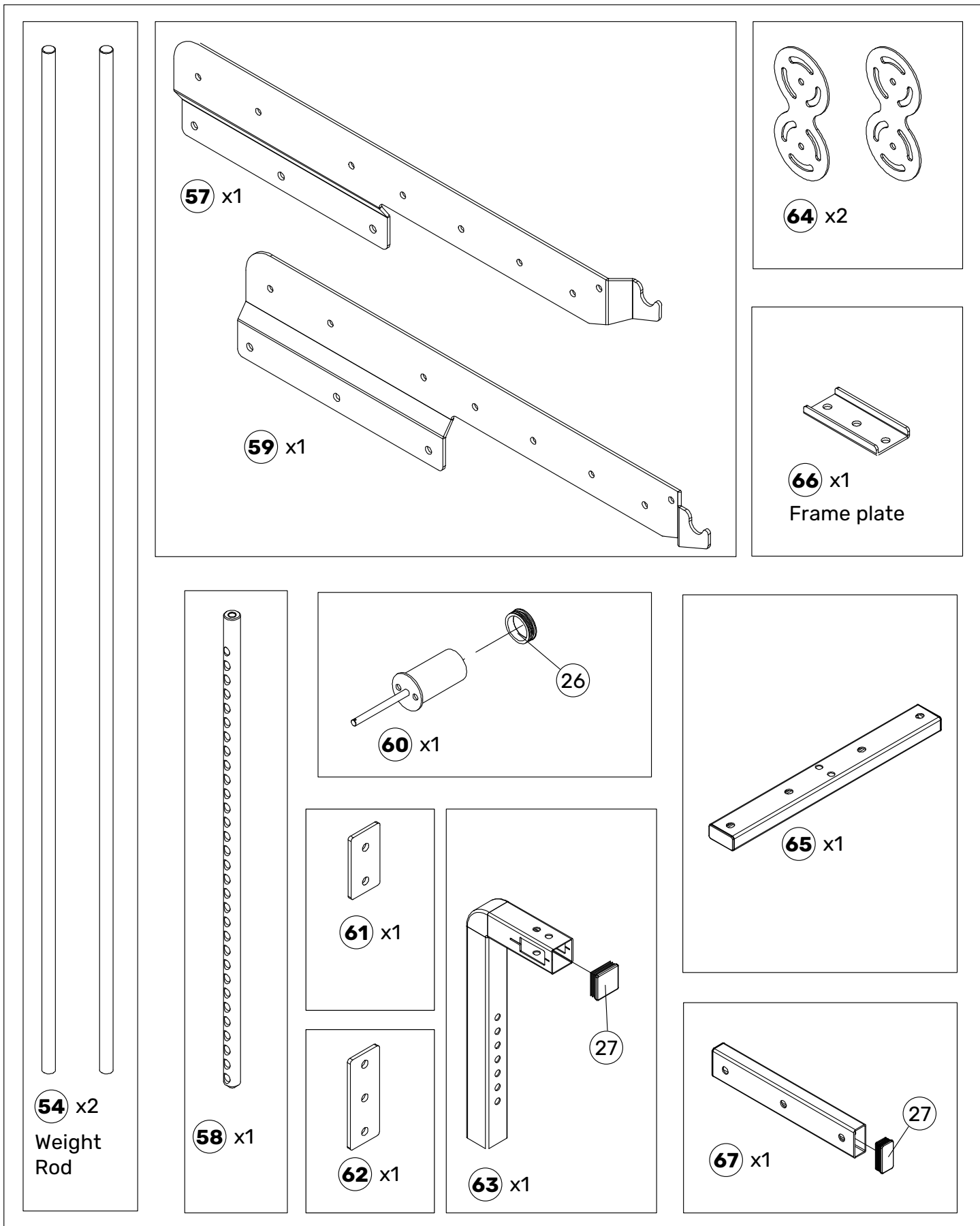

TOOLS REQUIRED

19mm
Wrench
x2

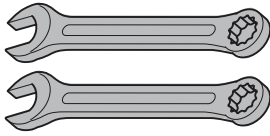

17mm
Wrench
x2

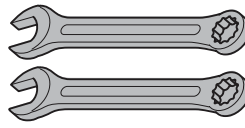

14mm
Wrench
x1

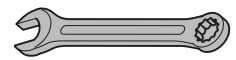

ASSEMBLY

- 1 Attach a 114 diameter pulley (33) to lower beam (46) using M10x45 (8), M10 washers and M10 nut.

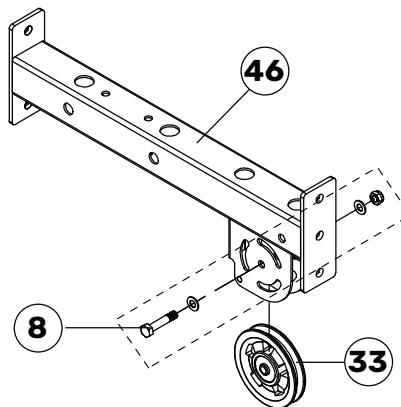
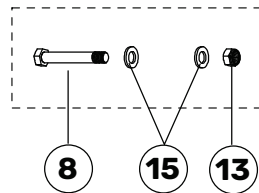

Do not overtighten.

- 2 Assemble (52) to (45) with 66 at the bottom. Fix with M12x85 bolt (1), M12 washer (12) and M14 nut (12).

- 3 Add the pre-assembled (46), and pre-assembled (49) to the newly assembled base in step 2. Fix with M12x85 bolt (1), M12 washer (14) and M12 nut (12). Do not forget to add (62) on the side of (52).

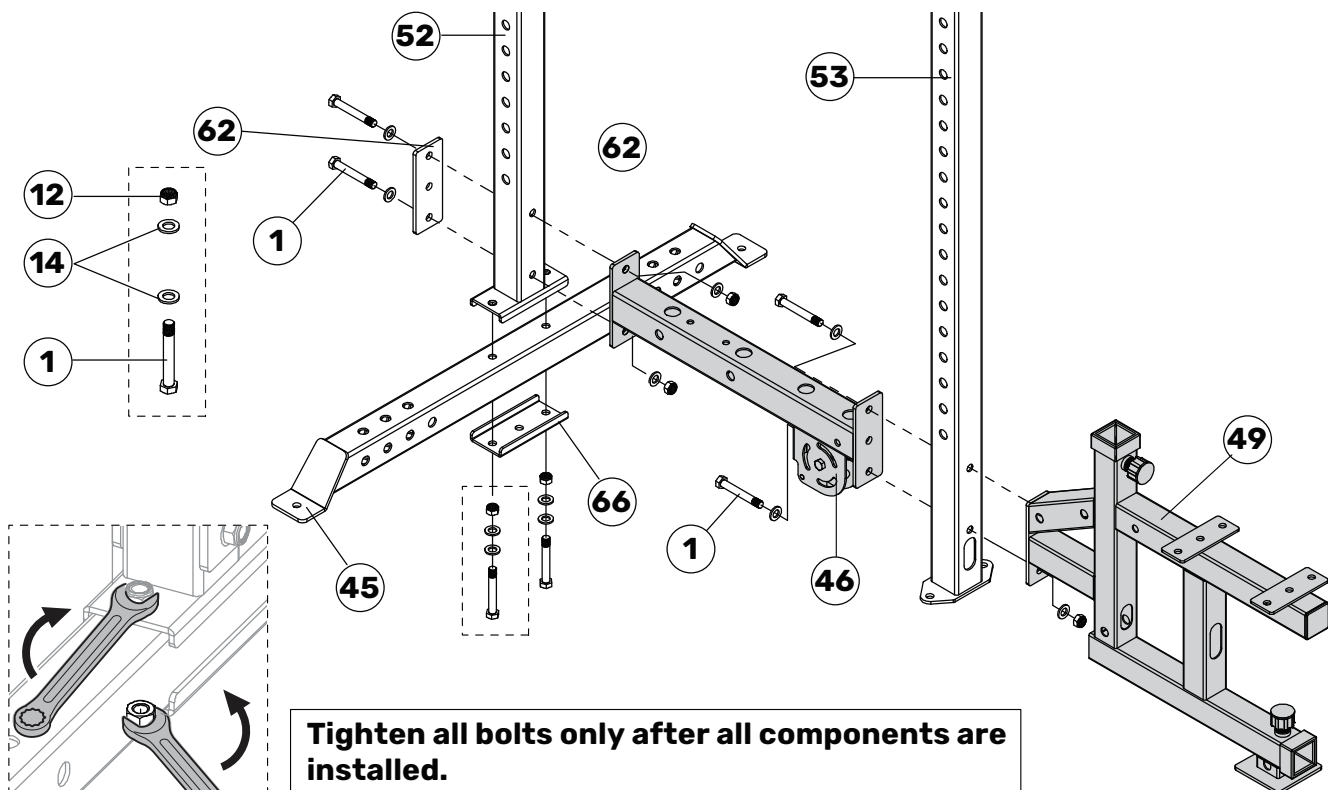

ASSEMBLY

4

Fix (47) to assembled frame. Fix with upper frame plate (61), M12x85 bolt (1), M12 washer (14) and M12 nut (12). Fix the top hole with M12x80 and M12 washer.

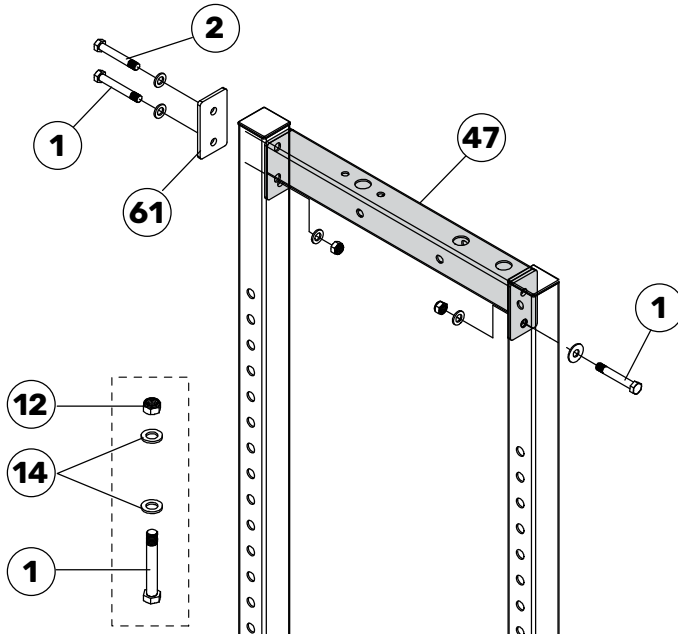

5

Attach (48) to frame. Fix with M10x80 bolt (4), M10 washer (15) and M14 nut (13).

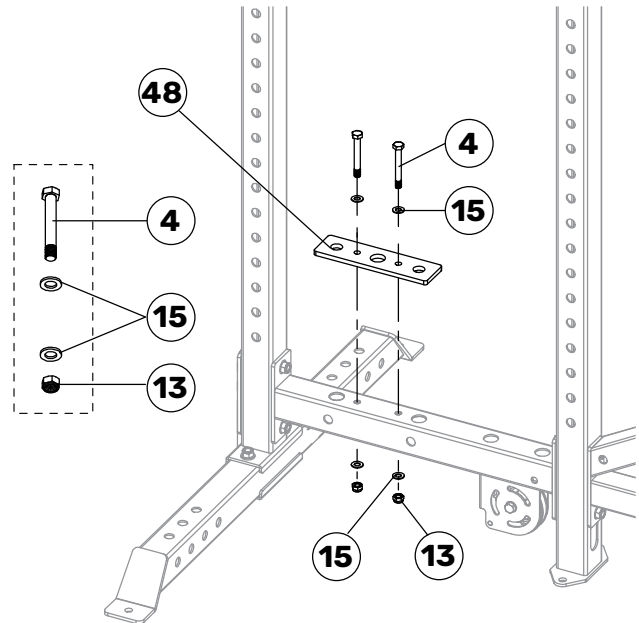

6

Attach 2 pieces of (34) below the base plates and attach (36) on both ends.

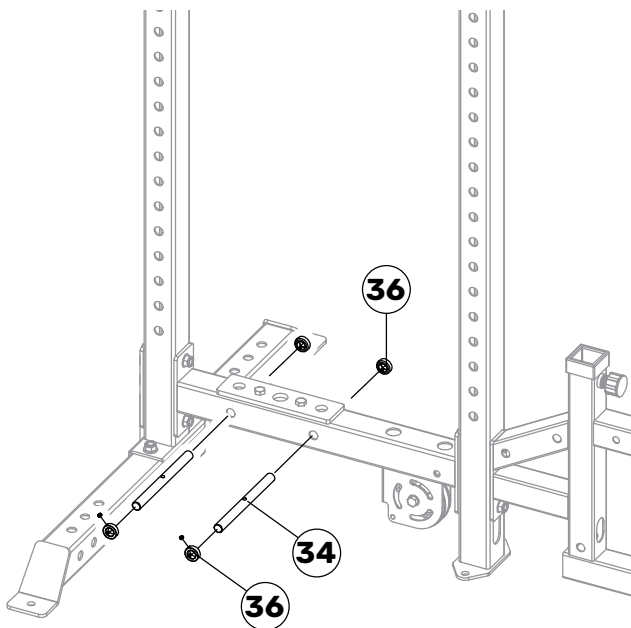

7

Attach 2 rods (54) and fix with M8x60 bolt (11) and M8 washer (16).

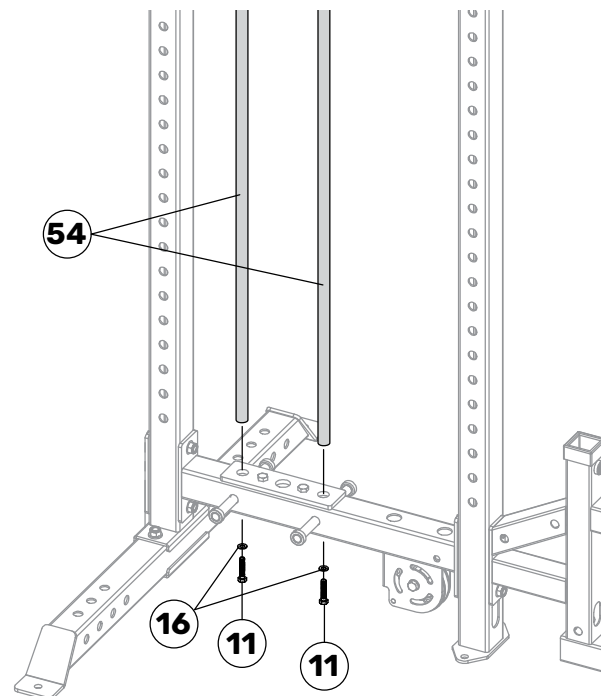

ASSEMBLY

8 Attach (29), then add the weight plates (39) as shown.

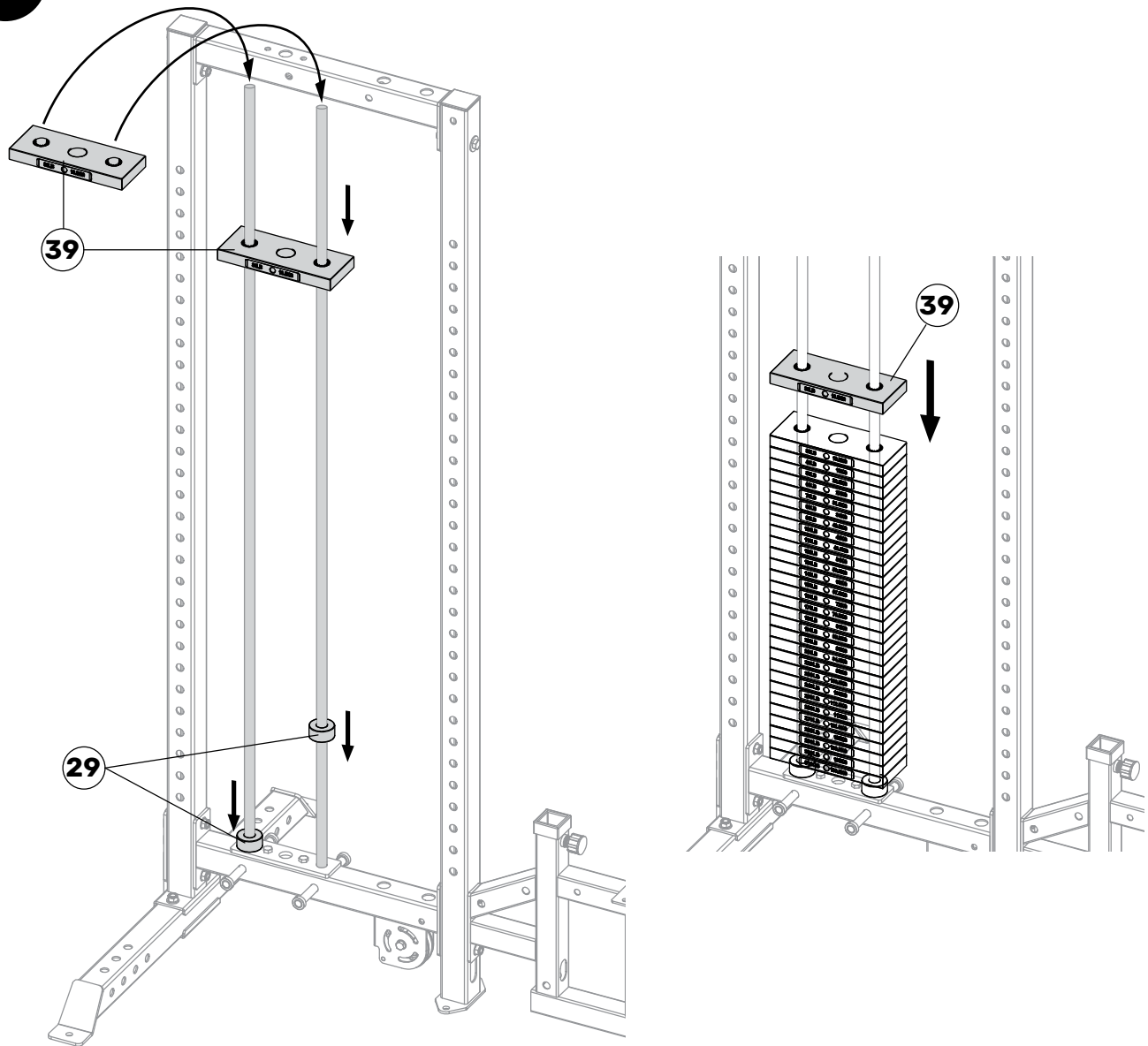

9 Attach stickers to weight stack as shown.

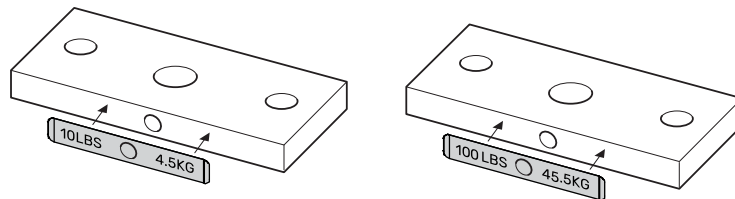

ASSEMBLY

- 10** Install pre-assembled weight stack assembly (19,37,58)

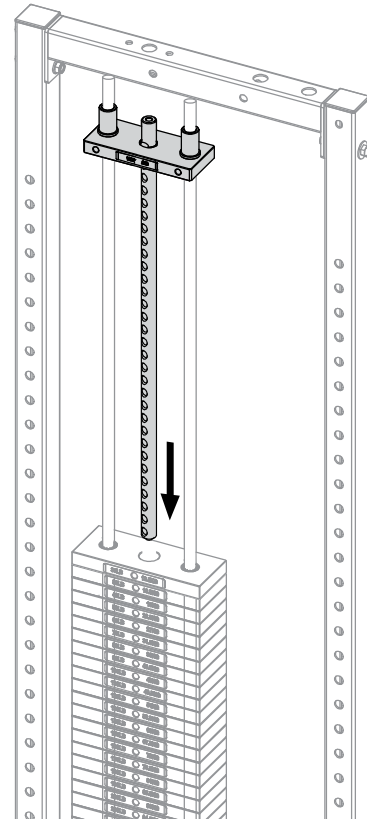

- 11** Install (35) and (36) as shown.

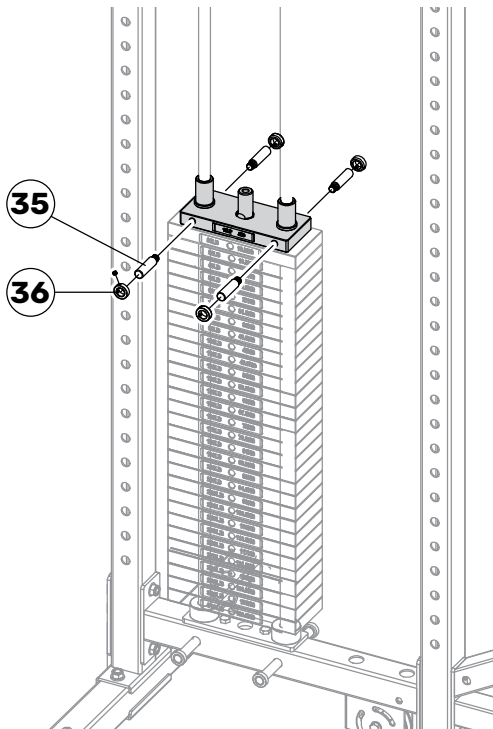

- 12** Add weight selector (31) to weight stack then install (48) onto the guide rods.

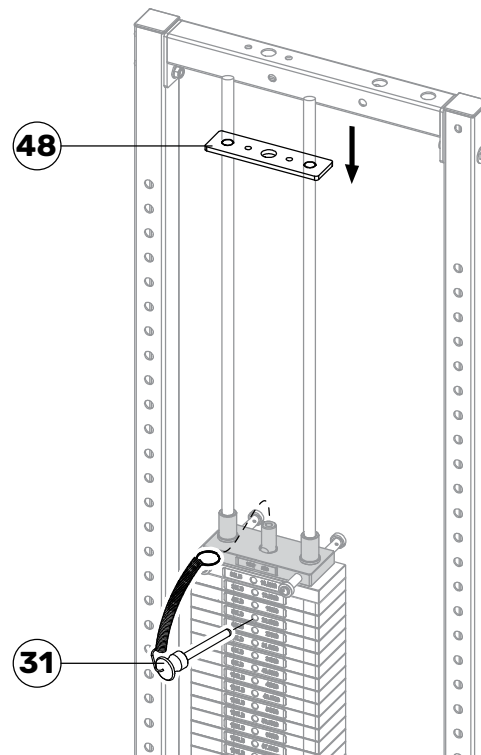

ASSEMBLY

- 13** Fix (48) to the top of rack with M10x80 bolt (4), M10 washers(15) and M10 nut (13).

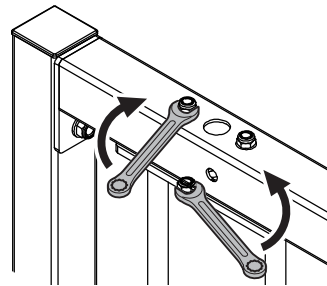
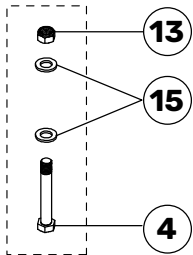

Tighten as shown

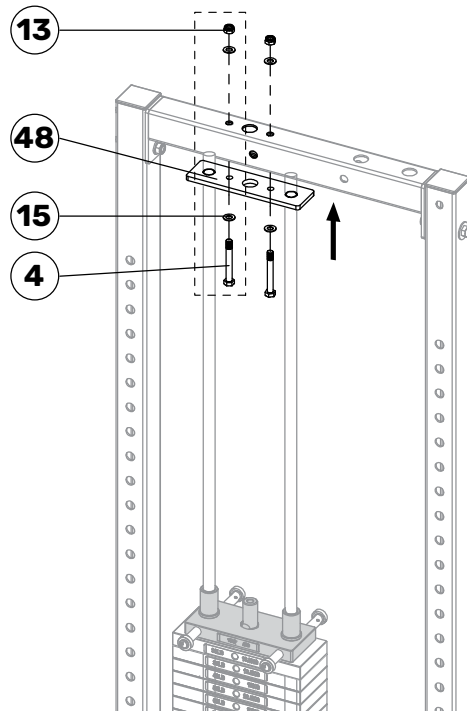

- 14** Attach (57) and (59). Fix with M12x85 bolt (1), M12 washer (14) and M12 nut (12).

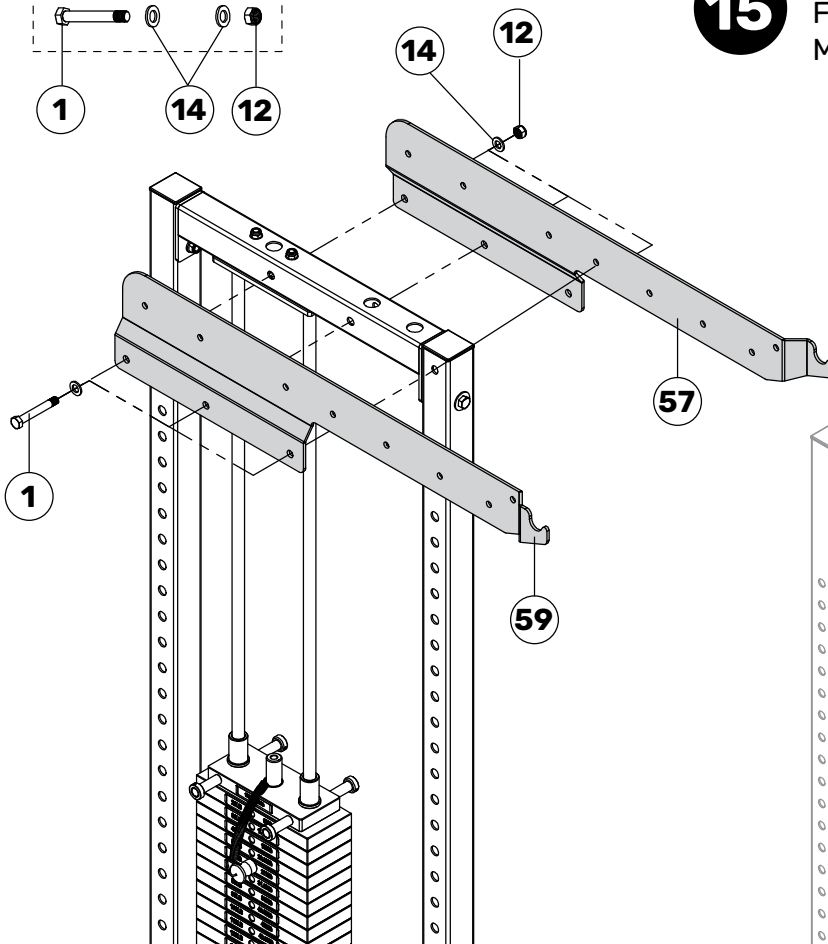
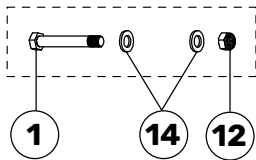

- 15** Attach pre-assembled (67). Fix with M10x50 bolt (7), M10 washer (15) and M10 nut (13).

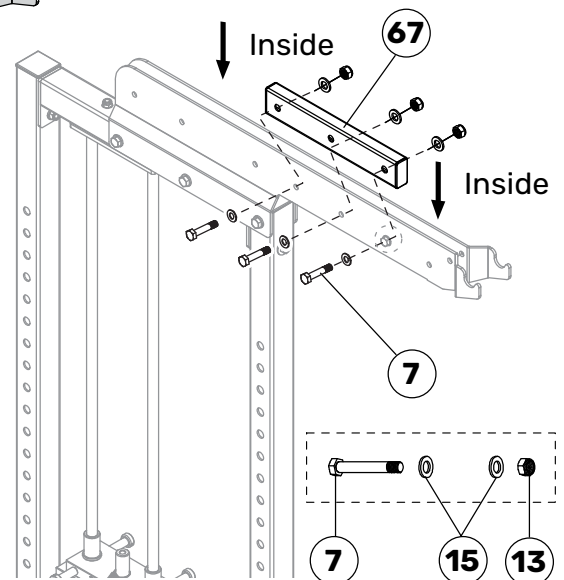
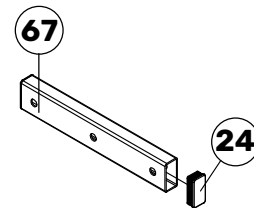

ASSEMBLY

16

Attach (28) and (60). Attach (43) and fix with M10x20 bolt (10) and M10 washer (15), then install (56 and 55).

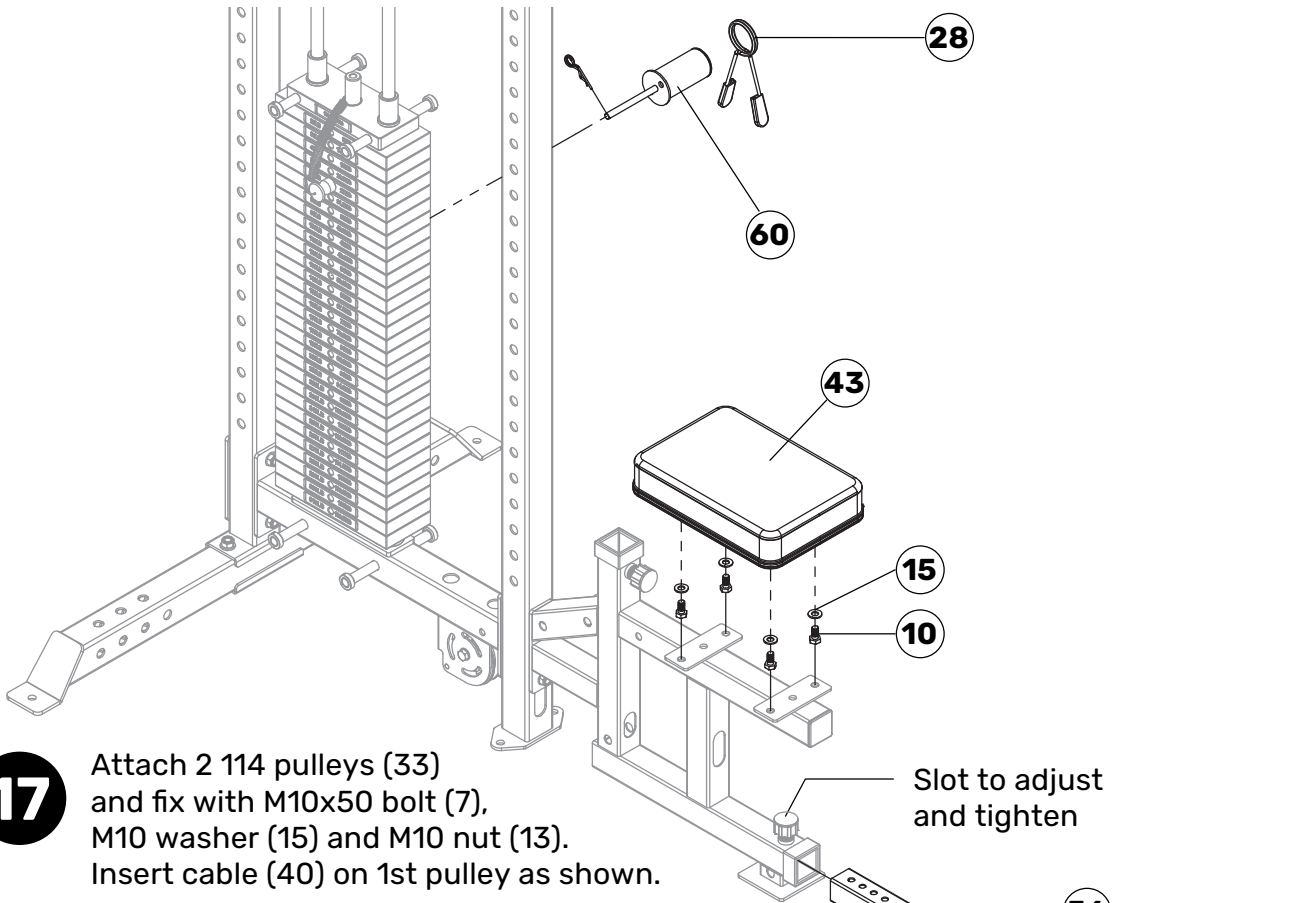

17

Attach 2 114 pulleys (33) and fix with M10x50 bolt (7), M10 washer (15) and M10 nut (13). Insert cable (40) on 1st pulley as shown.

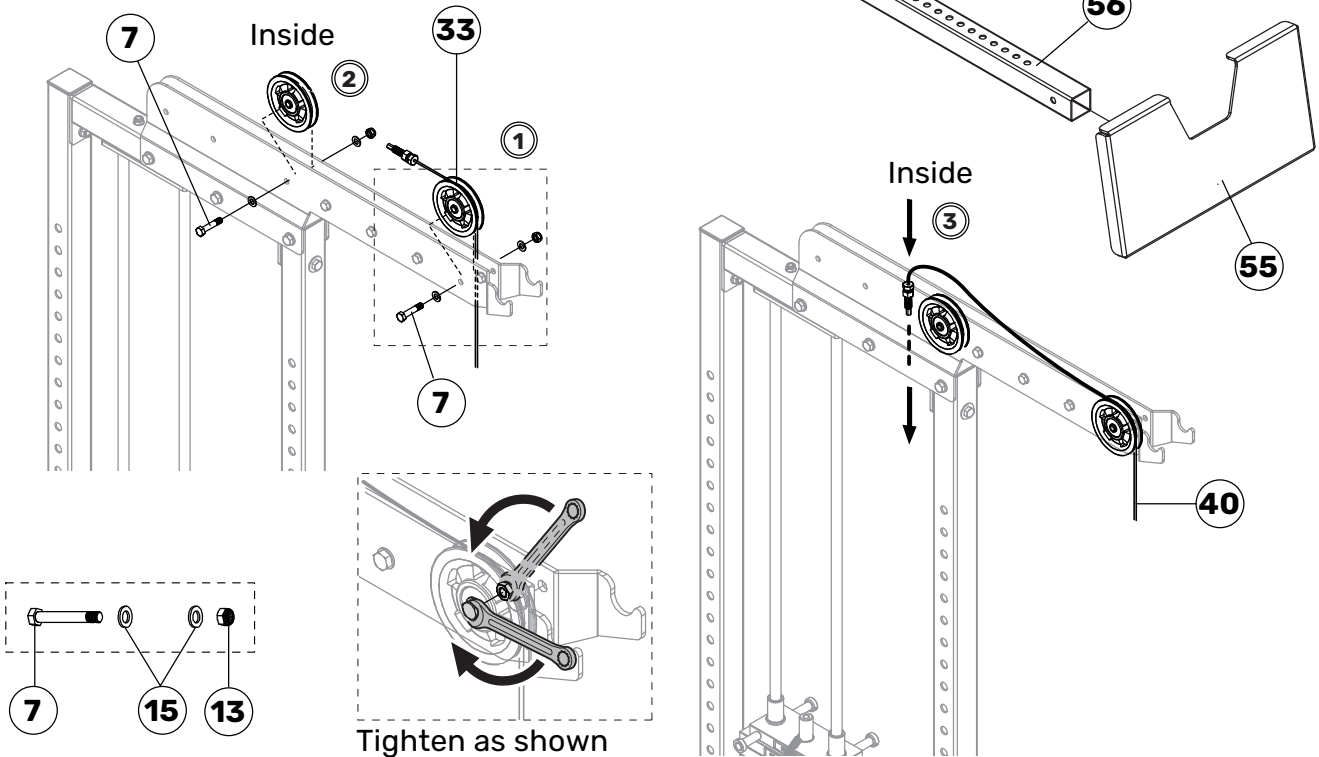

ASSEMBLY

- 18** Attach 2 114mm pulley (33) and fix with M10x50 bolt (7), M10 washer (15) and M10 nut (13).

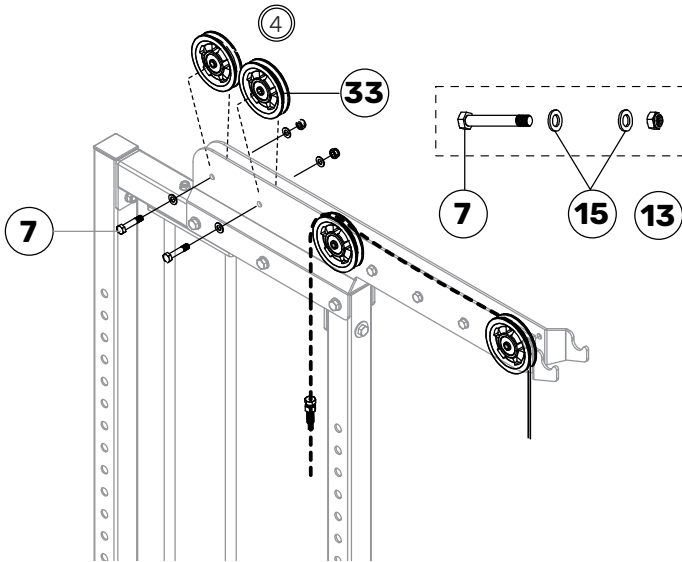

- 19** Fix the cable following the pulleys as shown.

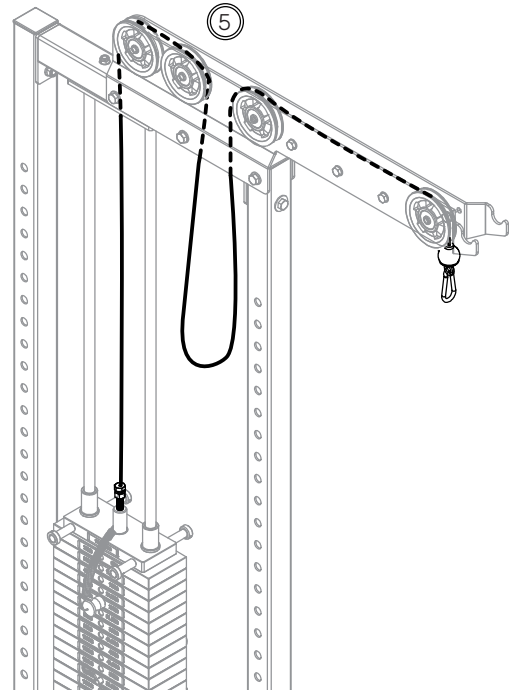

- 20** Install a 114mm pulley (33) between the 2 brackets (64) with M10x45 bolt (8), M10 washer (15) and M10 nut (13). Then install on the cable.

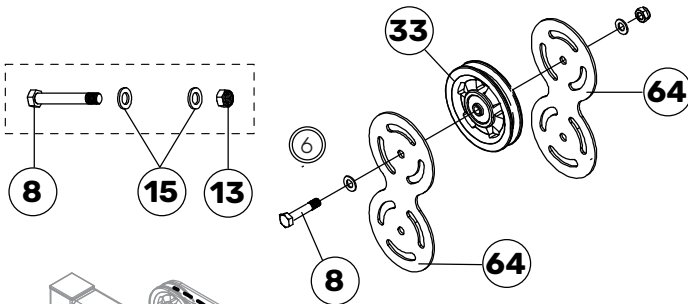

- 21** Insert cable (41) through the holes shown.

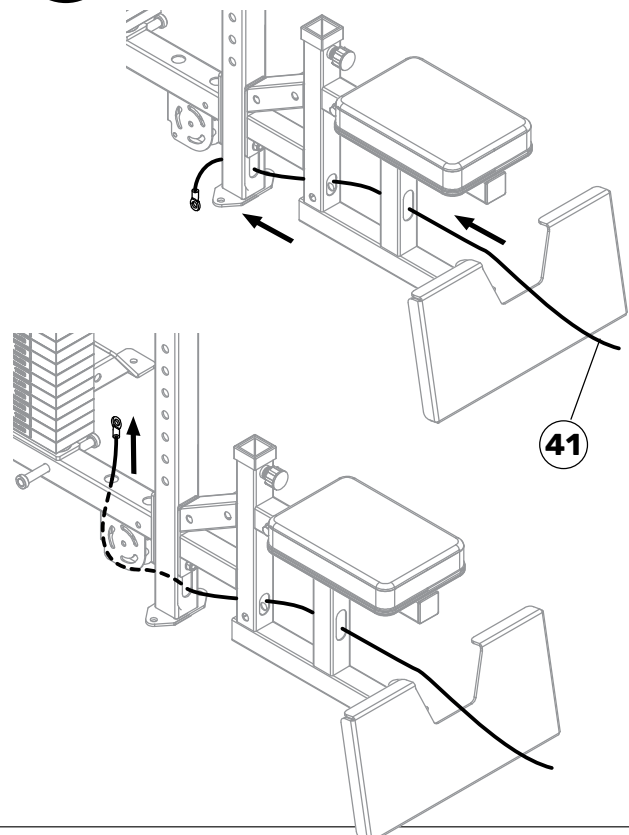

ASSEMBLY

- 22** Pull cable (41) up, and through the last 114mm pulley (33). Fix the pulley to the pulley holder (64) using M10x45 bolt (8), M10 washer (15) and M10 nut (13).

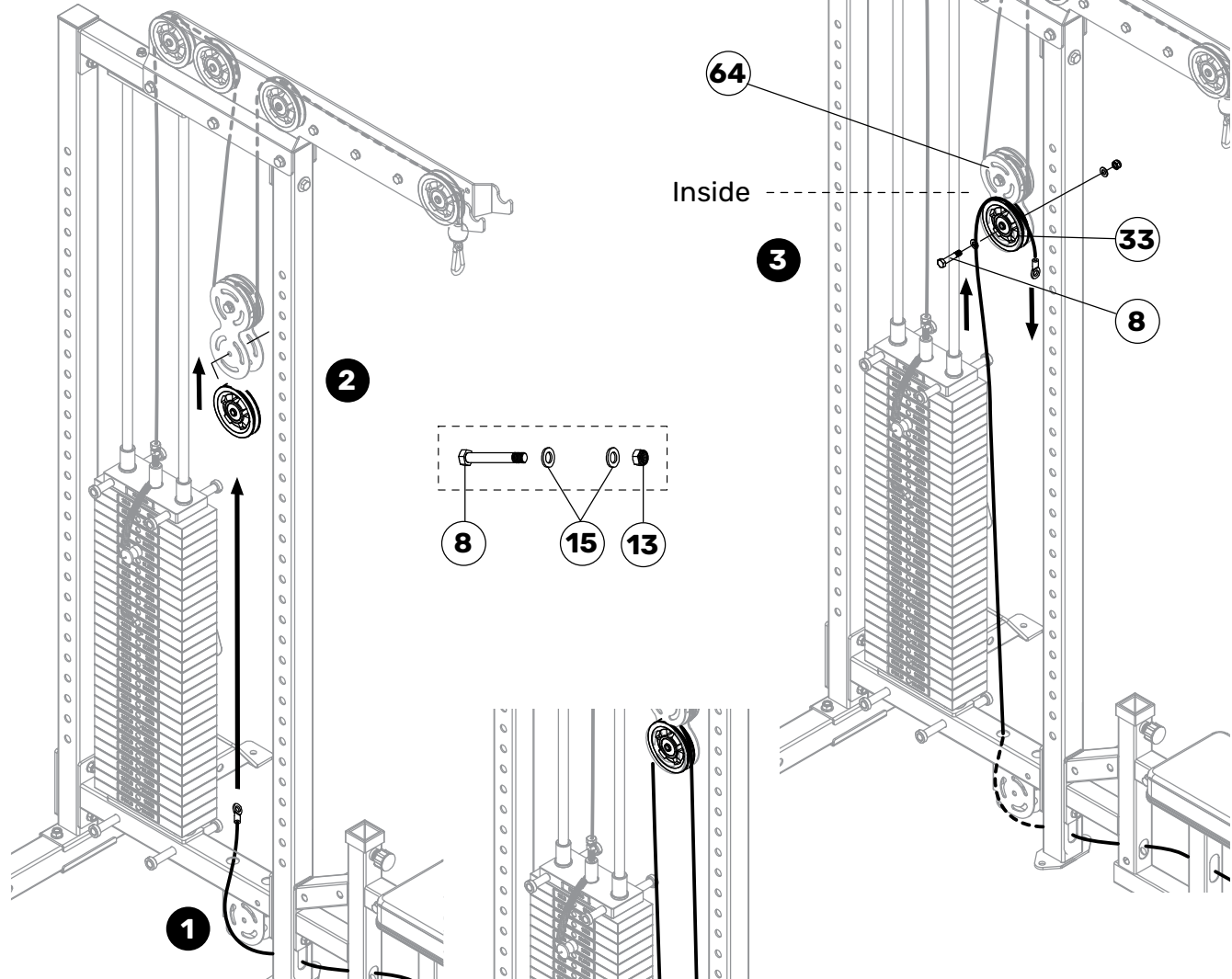

- 23** Pull cable (41) down and fix to the frame. Fix using M10x45 bolt (8), M10 washer (15) and M10 nut (13).

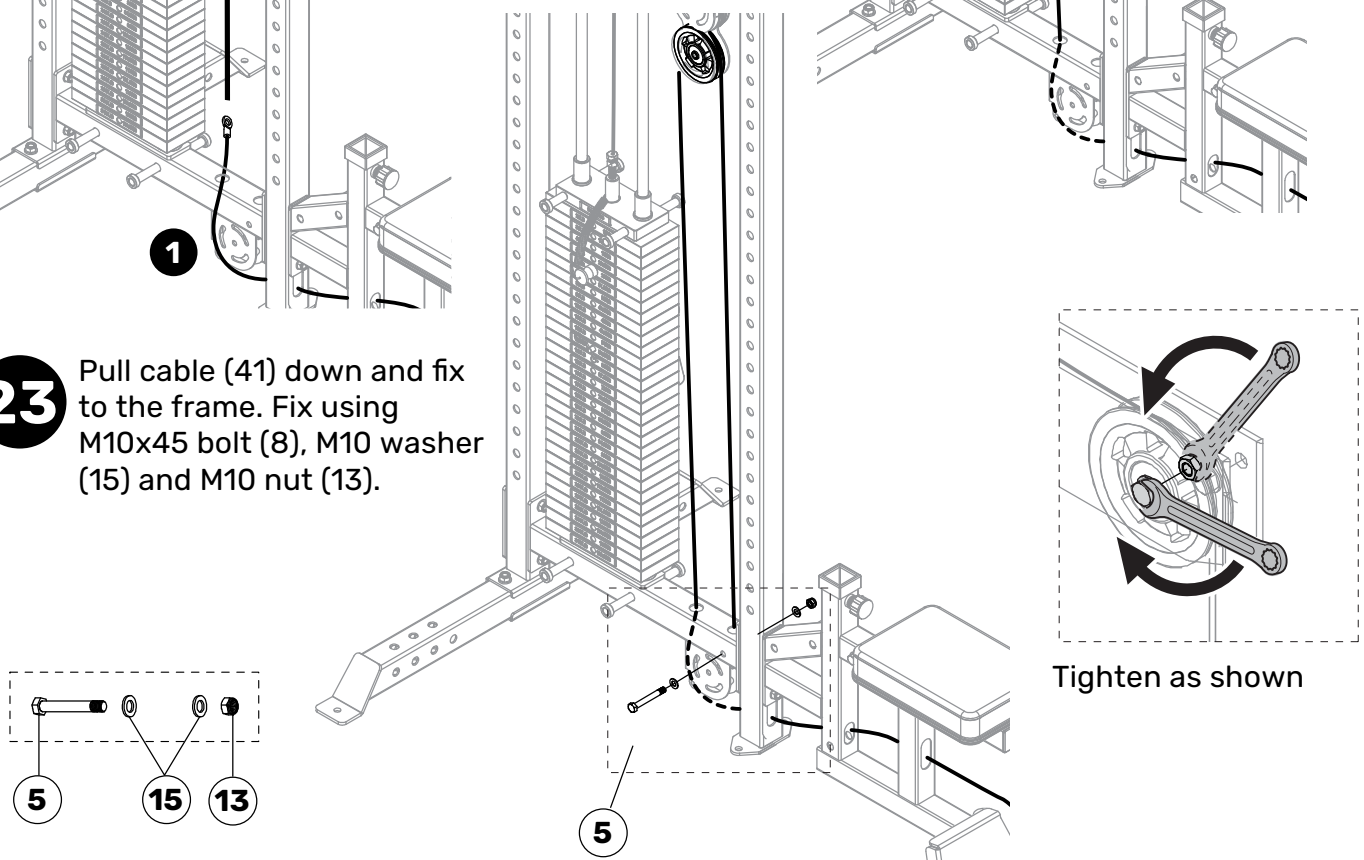

ASSEMBLY

24 Assemble (44) and (65).
Fix with M10x40 bolt (9)
and M10 washer (15).

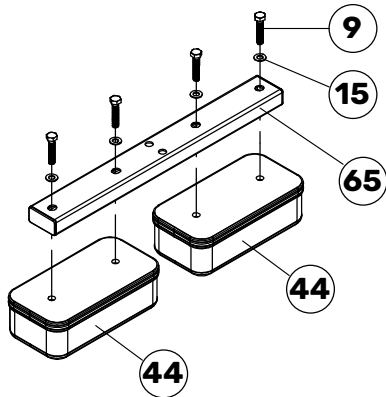

25 Attach (65) to (63) and fix with M10x60
bolt (6), M10 washer (15) and M10 nut (13).

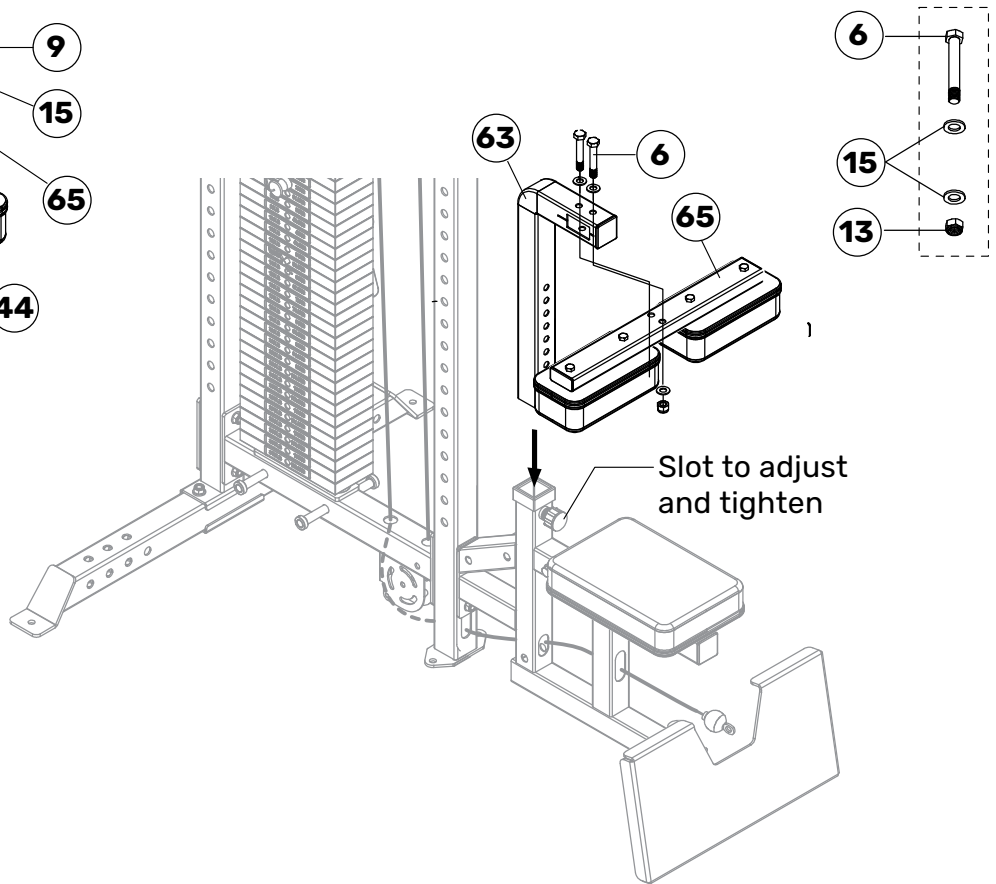

26 Install (50) and (51) on both sides. Fix with M12x70 bolt (3), M12 nut (12) and
M12 washer (14).

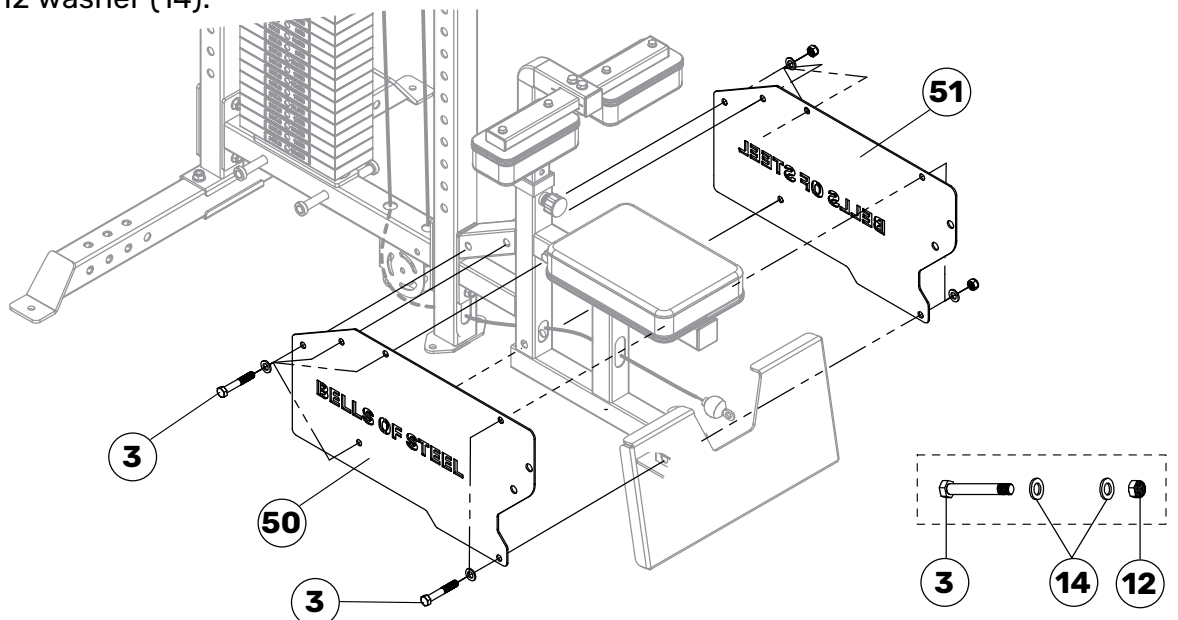

ASSEMBLY

- 27** Attach small pulleys (32) and fix with M10x75 bolt (5), M10 washer (15), pulley sleeve (18) and M10 nut (13).

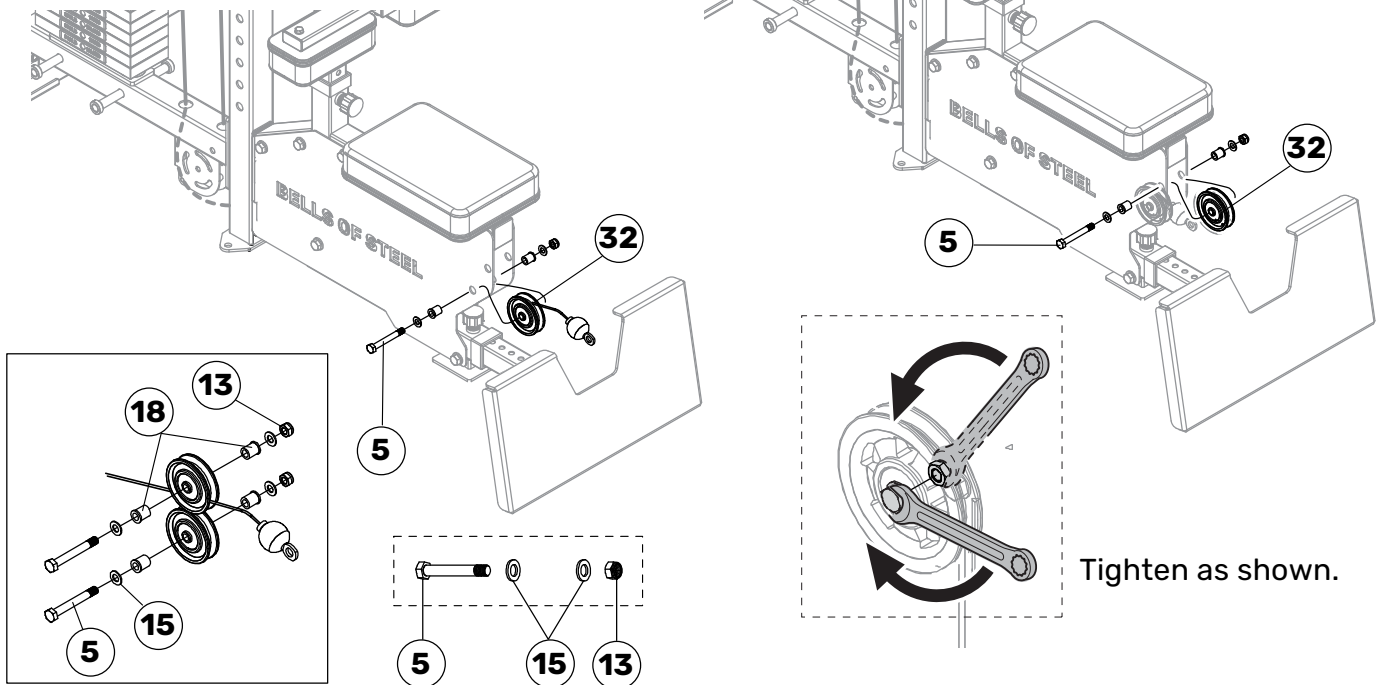

- 28** Attach the chain (42), carabiner (30) and handle (38).

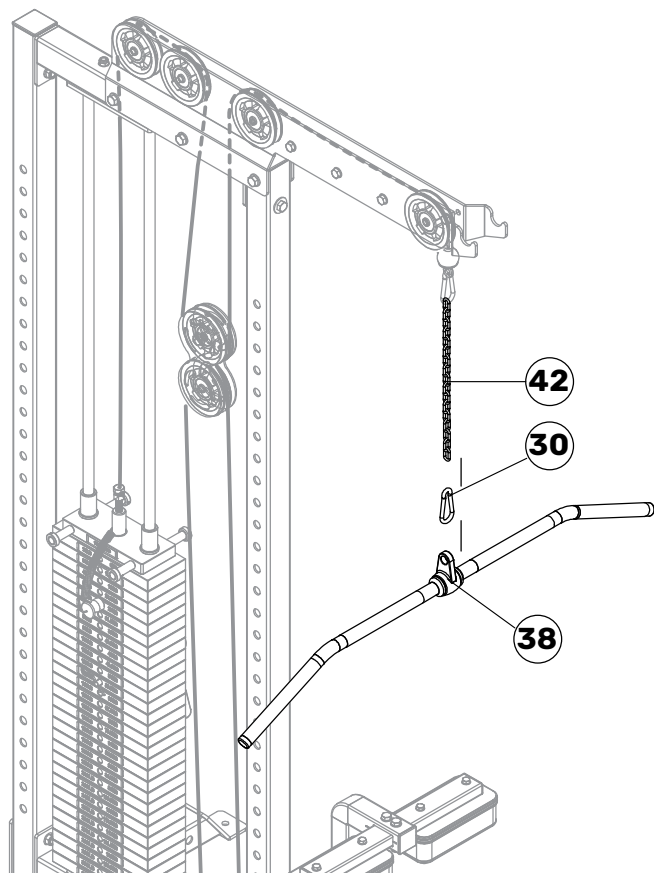

YOU'RE FINISHED!

**WANT TO LEARN MORE ABOUT THE BLITZ MAX AIR BIKE?
CHECK OUT THE OVERVIEW VIDEO:**



VISIT OUR SHOWROOMS



Calgary - HQ



Toronto - Showroom



Indianapolis - Showroom

Corporate Headquarters 7880 66 St SE, Calgary, AB, Canada
U.S.A. Headquarters 5925 W 71st St, Indianapolis, IN, U.S.A.
Toronto Store 39 Haist Ave # 2, Woodbridge, ON, Canada

support@bellssofsteel.com | 1-888-718-7997