

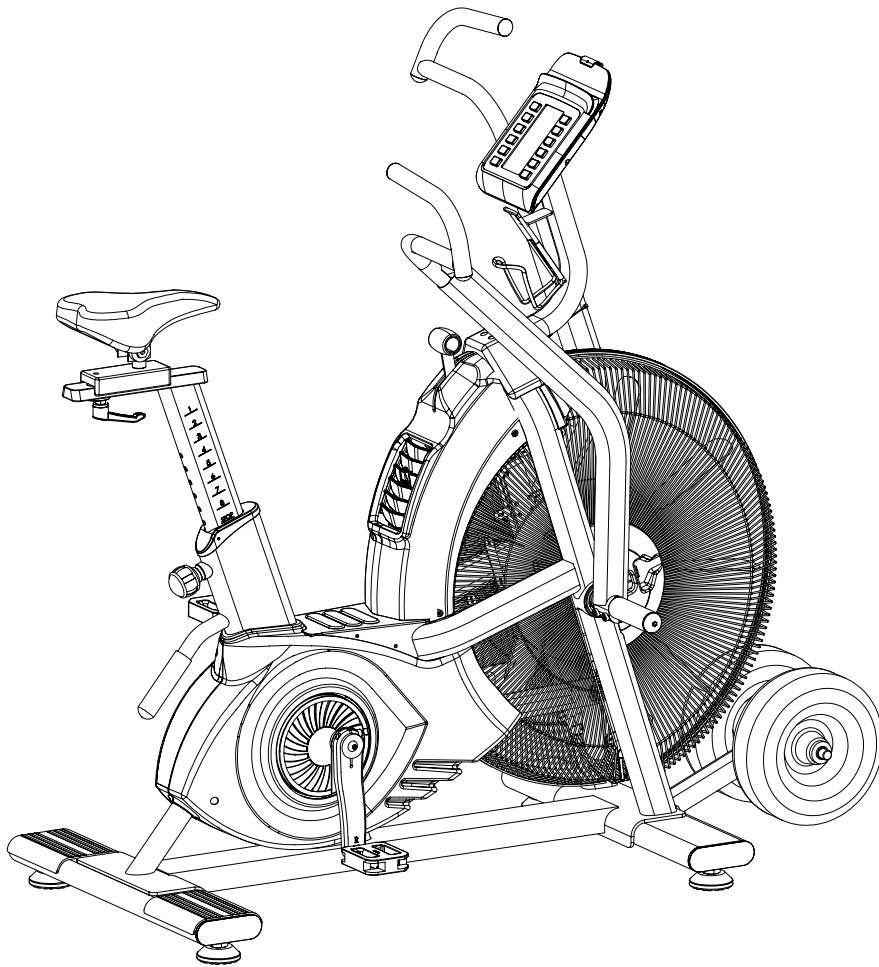

**BLITZ MAX AIR BIKE**  
**SKU: BMAX-AIRBK**  
**PO:**



## ASSEMBLY INSTRUCTIONS



**BELLSOFSTEEL**

**Stuck? Scan the QR code for the assembly video**

[www.bellssofsteel.com](http://www.bellssofsteel.com) | [www.bellssofsteel.us](http://www.bellssofsteel.us) | Telephone: 1-888-718-7997



# BUILDING STRENGTH, ONE BOLT AT A TIME.



## Welcome to Bells of Steel, you've made an excellent choice.

First off I want to say thank you for supporting my small business.

I've put significant thought into designing this product to enhance your lifting experience and help you reach your full potential. I hope you love it!

I've done my best to keep the setup of your new gear simple. If you find yourself needing a bit more assistance than the included instructions, check our youtube page for assembly videos or feel free to email us for troubleshooting guidance.

**Kaevon Khoozani**



Crush your Gains! Subscribe to our YouTube for workouts & how-to's.

**@BELLSOFSTEEL**



Warranty & returns? We got you covered—check here:

**[bellssofsteel.com/pages/warranty](https://bellssofsteel.com/pages/warranty)**

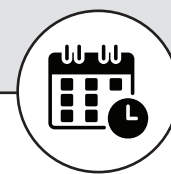

Changed your mind? No sweat. 30-day refund guarantee:

**[bellssofsteel.com/policies/refund-policy](https://bellssofsteel.com/policies/refund-policy)**



### Let us know how we've done

Love it? Leave a review! Hate it? We still read it. Help us get better by reviewing our products.



### Customer Notice

If you are missing any parts, or otherwise have any warranty issues/shipping damages, please file a warranty claim on our website.

Before discarding the box, please take clear photos of the box and shipping labels, as these may be required if parts are missing or the item is damaged.

# BEFORE WE BEGIN, LET'S STAY SAFE.



## A GUIDE TO SAFETY

---

We know you are excited to use your new Bells of Steel gear, but please read through this Guide to Safety to ensure you do not hurt yourself or others while exercising. It is your responsibility to ensure that all users of the equipment are informed of all warnings and instructions in this manual. TO REDUCE THE RISK OF SERIOUS INJURY, READ THE FOLLOWING IMPORTANT PRECAUTIONS BEFORE USING YOUR BELLS OF STEEL PRODUCT.

- ① Before starting any exercise program consult your physician. Be aware of your body's signals. Incorrect or excessive exercise can be damaging to your health. STOP EXERCISING IF YOU EXPERIENCE ANY OF THE FOLLOWING SYMPTOMS: PAIN, TIGHTNESS IN YOUR CHEST, IRREGULAR HEARTBEAT, SHORTNESS OF BREATH, LIGHTHEADEDNESS, DIZZINESS, OR FEELINGS OF NAUSEA. IF YOU EXPERIENCE ANY OF THESE SYMPTOMS, STOP EXERCISING IMMEDIATELY AND CONSULT YOUR PHYSICIAN BEFORE CONTINUING WITH YOUR EXERCISE PROGRAM.
- ② It is your responsibility to ensure there is enough space around the product for the intended exercise. Use the product on a flat surface and ensure at least 2 feet (60 cm) of free space around it.
- ③ Children and pets must not be let on or near the product. Moving parts and heavy features of the product can be dangerous and cause serious injury.
- ④ Read all instructions in this manual before using the product and use the product only as described in this manual.
- ⑤ It is your responsibility to ensure that all users of the product are adequately informed of all precautions, have read and understand all warnings, and are informed how to use the product properly.
- ⑥ Keep hands and feet from moving parts. Do not lean or rest on the product.
- ⑦ Wear athletic shoes for foot protection while exercising.
- ⑧ Your product is intended for use in cool, dry conditions. You should avoid storage in extreme cold, hot, or damp areas.
- ⑨ This product is designed for indoor use only.
- ⑩ Ensure that any weight pins that may be included with your product are completely inserted into an appropriate weight plate.
- ⑪ Ensure that any handles that may be included with your product are attached securely before using the product.
- ⑫ Ensure that any nuts and bolts that may be included with your product are securely tightened before use. Regularly re-tighten nuts and bolts.
- ⑬ Ensure any cables that may be included with your product always remain attached to their proper pulleys. If a cable bind occurs during exercise, stop immediately and inspect the part to ensure any interference is fixed.
- ⑭ Do not overexert yourself during any exercise program. Operate the product as intended.
- ⑮ The product should be anchored where required or whenever possible. The product should be secured when not in use.
- ⑯ The product is very heavy. Improper use or assembly can lead to serious injury or death.
- ⑰ SAVE AND REVIEW THESE INSTRUCTIONS.

NOW...

## LET THE GAINZ BEGIN

# Exploded Drawing

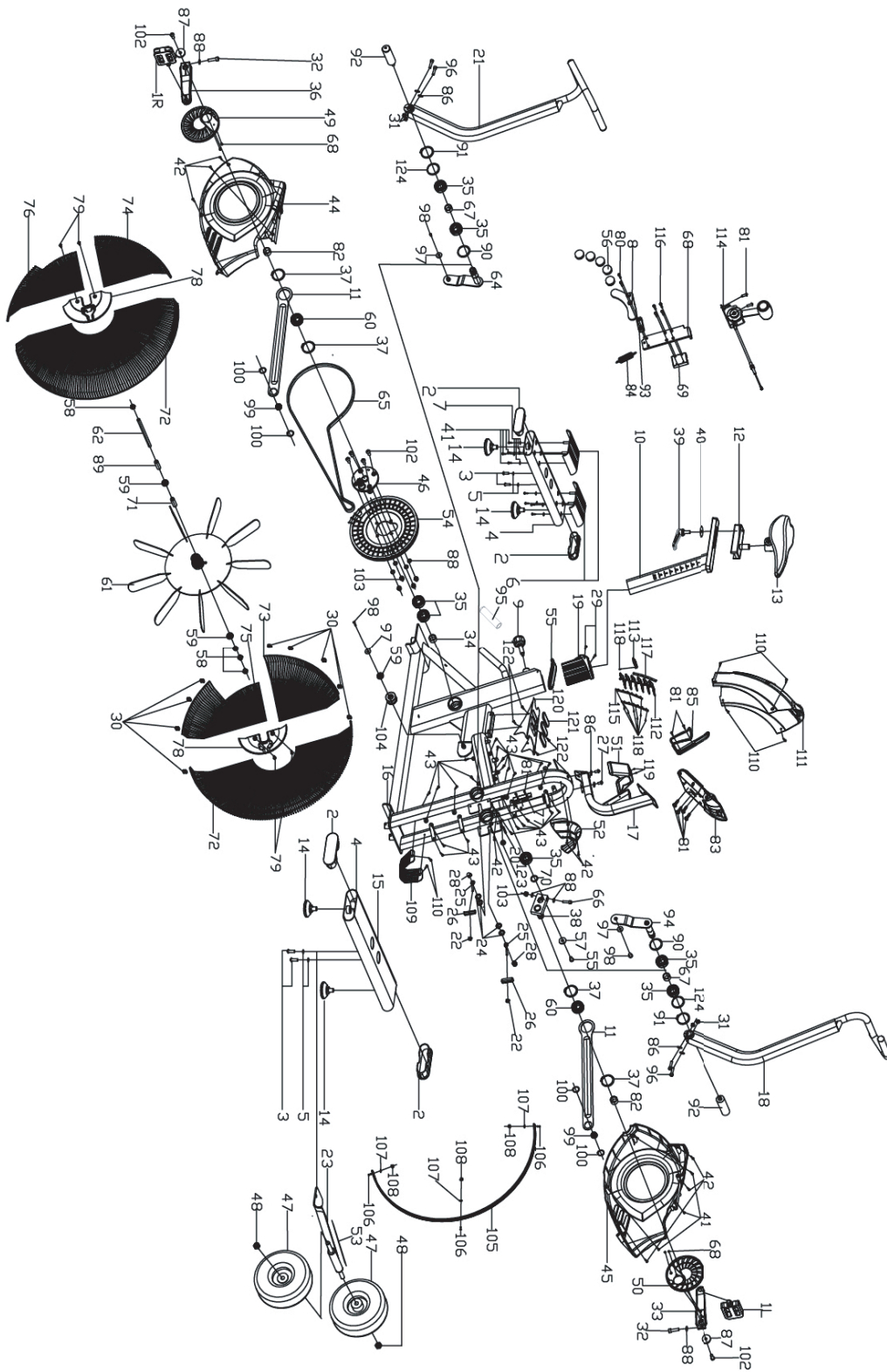

# PARTS LIST

NO	NAME	QUANTITY	SPEC
1	PEDAL	1	JD-308V (9/16")
2	END CAP3	4	120*40*35
3	BOLT 1	4	GB/T 70.2-2000 M10*30
4	REAR STABILIZER	1	WELDING
5	FLAT WASHER	6	GB/T 95-2002 10
6	FRONT COVER	2	160*128*3
7	BOLT 1	4	GB/845-85 ST4.8X19
8	Large Roller Support Frame	1	WELDING
9	SHAPE KNOB	1	φ50*91 (M16*35),
10	VERTICAL SEAT POST	1	WELDING
11	Drive assembly	2	WELDING
12	SEAT POST	1	WELDING
13	SEAT	1	KX98-7
14	STOPPER	4	φ70*41/(M16X25)
15	FRONT STABILIZER	1	WELDING
16	MAIN FRAME	1	WELDING
17	Electronic watch connecting	1	WELDING
18	The left handlebar assembly	1	WELDING
19	PLASTIC SLEEVE	1	103*53.5*178
20	SENSOR	1	SR-202
21	Right handlebar assembly	1	WELDING
22	NUT	6	GB/T 889.1-2000 M6
23	FIXING NUT 2	1	φ44.8*16.5
24	FLAT WASHER	2	GB/T 95-2002 12 (H=2)
25	FIXING BOLT	2	M6*60
26	Pull out the fixed piece	2	δ1
27	BOLT 1	8	GB/T 70.2-2000 M8*16
28	NUT	10	M12X1.25 H=8MM
29	CRANK END CAP	4	φ28*6.5
30	Sprocket buckle	9	δ1
31	NUT	8	GB/T 889.1-2000 M8
32	PLASTIC RING	1	φ56*28
33	LEFT CRANK	1	170*15
34	LONG FIXING TUBE	1	φ25*φ20.2*41.2
35	BEARING	2	6004ZZ
36	RIGHT CRANK	1	170*15
37	Outer spring	4	42
38	Crank drive assembly	2	80*65
39	COVER	2	56*23.6*24.6
40	COVER	2	58*36.3*22.7
41	SCREW 1	6	GB/T 845-1985 ST4.2*19
42	SCREW 2	17	GB/T 845-1985 ST4.2*16
43	SCREW 3	6	GB/845-85 ST4.8X19
44	CHAIN COVER 1	1	478*270*60
45	CHAIN COVER 2	1	469*241*23
46	AXIS	1	φ20*162
47	BOLT 7	6	GB/T 70.1-2000 M4*12

# PARTS LIST

48	BOLT 8	1	GB/T 70.1-2000 M5*18
49	Sweat proof cover	1	438*194*399
50	SHORT CHAIN WHEEL	1	12.7, 66
51	BELT WHEEL	1	P=12.7,Z=52T
52	FRONT COVER	1	122*56*45
53	Handle base	1	41.5*30*30
NO	NAME	QUANTITY	SPEC
54	LOCK NUT	2	M33*1*4
55	CHAIN WHEEL 1	1	A7K-16 1/2"*1/8" 16T (1.37")
56	Large Rubber Rollers	2	φ250*89
57	FIXING NUT	1	M20*1.0
58	FIXING NUT 2	3	M12X1.25 H=6
59	BEARING	6	60012Z
60	BEARING	2	6004ZZ
61	Rim assembly	1	φ640*69
62	FLYWHEEL SHAFT	1	φ12*160
63	Double drive assembly	1	φ110*107
64	Double drive inner sleeve	1	φ16*φ12.2*91.1
65	BELT	1	5PK53
66	CHAIN COVER 3	1	248*269*80
67	SHORT FIXING TUBE	1	φ25*φ20.5*9
68	BOLT 1	2	GB/845-85 M4*12
69	Handle	1	79*32*32.6
70	NUT	2	GB/T 889.1-2000 M16 H=12
71	Flywheel inner casing	1	φ16*φ12.2*53.1
72	BOTTLE HOLDER	1	φ6
73	SCREW 3	6	GB/T 5780-2000 M5*10
74	The left wheel cover	1	φ690*55
75	Right wheel cover	1	φ690*55
76	Fan baffle	1	φ170*10
77	Handle rotary copper sleeve	1	φ12*20
78	BOLT 3	2	M10*50
79	NUT	2	GB/T 889.1-2000 M10 H=15
80	BOLT 16	1	M6*35,
81	Handle cover	1	φ16.4*10.3*5.5
82	NUT	2	GB/T 889.1-2000 M14*1.5 H=10mm
83	COMPUTER	1	JSD-10421,
84	Universal joint	2	82*30 (M14*1.5)
85	Foot lever	2	φ38*120(M16*1.5)
86	BEARING	4	6203ZZ
87	Foot lever	2	φ22*110(M16*1.5)
88	Foot lever bushing	2	φ24*φ17.2*11.1
89	Small retaining plate	4	δ3
90	corrugated gasket	4	φ20
91	FIXING NUT 1	1	M12X1.25 H=10
92	WASHER	2	GB/T 859-1987 16
93	FIXING BOLT	4	M6*56
94	Fan baffle	1	φ170*10

## PARTS LIST

---

95	SPRING WASHER	2	GB/T 859-1987 10
96	SPRING WASHER 2	10	GB/T 859-1987 8
97	BELT WHEEL	1	φ200*21
98	Plastic plug	1	φ14*
99	EVA	1	280*50*σ3.0,
100	Serrated gasket	4	GB/T 95-2002 12
101	SCREW 2	2	GB/T 845-1985 ST4.2*25
102	BOLT 2	2	M8*25
103	WASHER	2	φ8
104	FLYWHEEL SHAFT 2	1	φ12*160
105	BOLT 9	2	GB/845-85 ST4.2X6
106	Plate Shield	2	/78*59*55
107	corrugated gasket 2	2	φ17
108	Large gasket	4	GB/T 95-2002 Φ16*Φ6 (H=3)

# ASSEMBLY INSTRUCTIONS

## 1. Preparation:

- A. Ensure you have enough space around the item before starting assembly.
- B. Use the provided tools for assembly.
- C. Before beginning, verify that all the required parts are available. Refer to the exploded diagram at the beginning of this instruction manual, which lists all the parts (indicated by numbers) included in the package.

## 2. Assembly Instructions:

### STEP 1 (FIG. 1):

1. Attach the Front Stabilizer (15) to the Main Frame (16) using two sets of Flat Washers (5) and Bolts (1).
2. Attach the Rear Stabilizer (4) to the Main Frame (16) using two sets of Flat Washers (5) and Bolts (1).

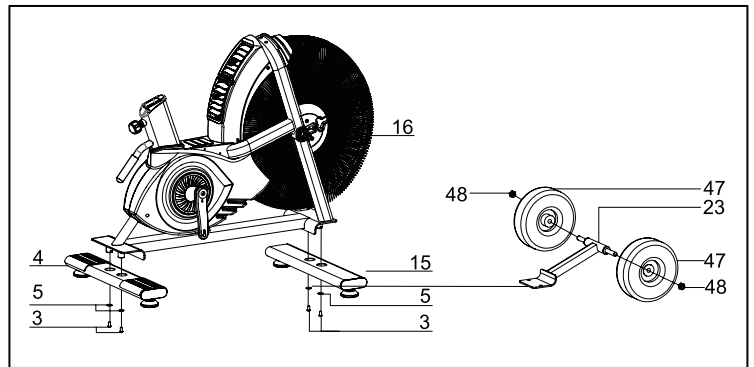

Fig. 1

### STEP 2 (FIG. 2):

1. Slide the Seat Post (12) into the Vertical Seat Post (10).
2. Pull the knob (9) to adjust the seat to the desired height, then release the knob and retighten the knurled portion.
3. Attach the Seat (13) to the Seat Post (12) as shown and tighten the screws under the seat to secure it.

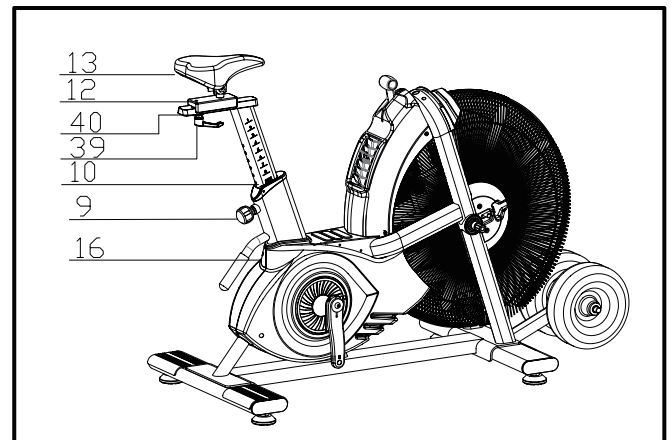

Fig. 2

### STEP 3 (FIG.3):

1. Insert the Left Handlebar Assembly (18) and the Right Handlebar Assembly (21) into the Main Frame Assembly (16) as shown in the diagram.
2. Secure them in place using Bolts (96), Washers (86), and Nuts (31).

**Note:** The arm bolts have different orientations. The right arm bolts need to be inserted from back to front, while the left arm needs to be inserted from front to back.

3. Attach the Pedal Screw (92) to the Main Frame Assembly (16).
4. Connect the plugs (A3 & A4), then attach the Display Assembly (17) to the Main Frame Assembly (16) using Bolt (27) and Washer (86).
5. Use Screw (119) to secure the Cover (51) to the Display Assembly (17).
6. Finally, connect the plugs (A1 & A2) and fix the Computer (83) onto the Display Assembly (17) using Screws (84).

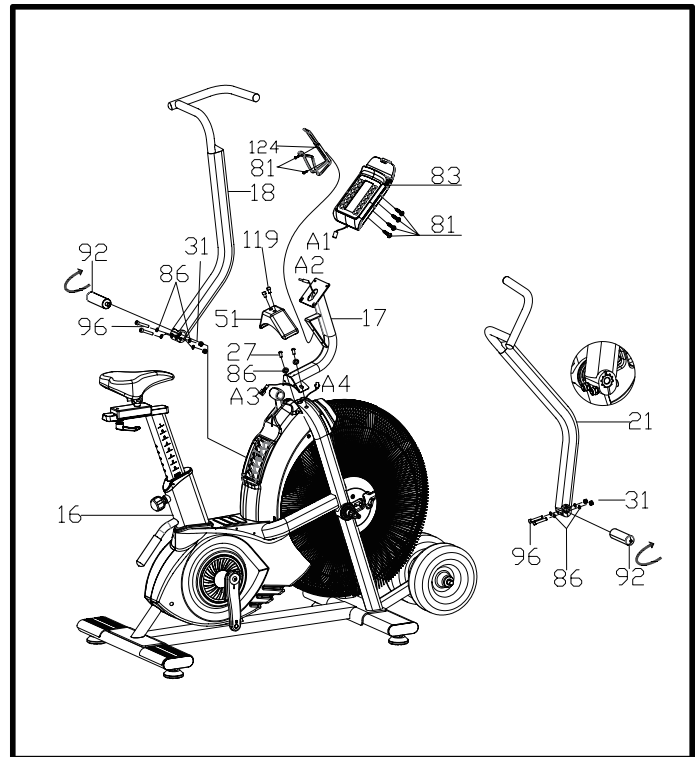

Fig. 3

### STEP 4 (FIG.4):

1. The Pedals (marked as 1L and 1R) are labeled "L" for Left and "R" for Right.
2. Attach the pedals to their corresponding crank arms. The Right Crank Arm is located on the right-hand side of the cycle when you are seated.
3. Note: The Right Pedal must be threaded clockwise, while the Left Pedal must be threaded counterclockwise.

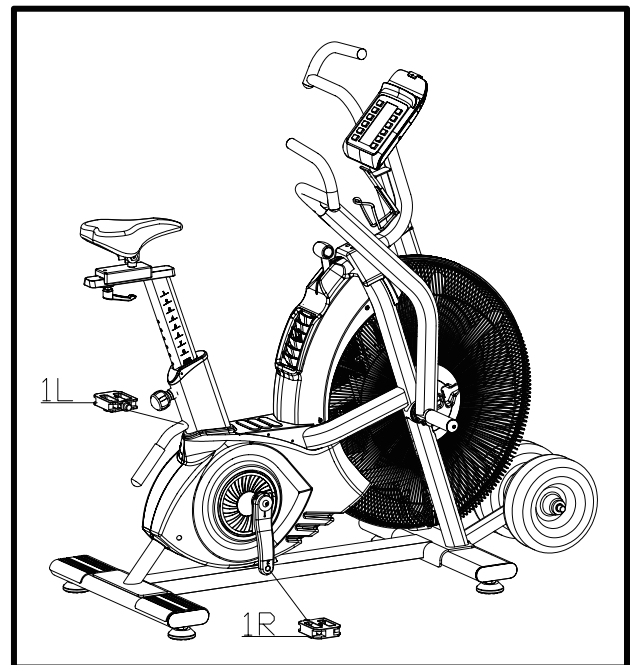

Fig. 4

Fig. 4

# ADJUSTMENT

---

## To Adjust the Seat Height:

Loosen the spring knob on the vertical post stem located on the main frame and pull the knob out. Adjust the vertical seat post to the desired height, ensuring the holes are aligned. Once aligned, release the knob and tighten it securely.

## To Adjust the Seat Position (Forward or Backward):

Loosen the adjusting knob and washer. Slide the horizontal seat post to the desired position, either forward toward the handlebar or backward away from it. Securely retighten the adjusting knob.

# MONITOR INSTRUCTION MANUAL

---

## Display Functions:

### TIME:

- Displays the user's workout time.
- Range: 0:00–1:59:00.

### DISTANCE:

- Displays the user's workout distance.
- Range: 0.5–100.

### CALORIES:

- Displays calorie consumption during the workout.
- Range: 0–2000.

### PULSE:

- Displays the user's heart rate during the workout.
- Range: 30–230.

### WATT:

- Displays power consumption during training.

### SPEED:

- Displays power consumption during training.

### RPM:

- Displays the current training RPM (Revolutions Per Minute).

## **Button Functions:**

### **1. Up (▲)**

- Adjusts the function value upward.

### **2. Down (▼)**

- Adjusts the function value downward.

### **3. Enter**

- Confirms settings or selections.

### **4. Start**

- Starts the workout quickly or resumes the workout in stop mode.

### **5. Stop**

- Stops or pauses the workout.
- Hold for 2 seconds to reboot the console.

### **6. Interval**

- Provides access to three interval programs: INTERVAL 10/20, INTERVAL 20/10, and Custom Interval.

### **7. Target Distance**

- Provides fast access to the Target Distance training mode.

### **8. Target Calories**

- Provides fast access to the Target Calories training mode.

### **9. Target Heart Rate**

- Provides fast access to the Target Heart Rate training mode.

### **10. Target Time**

- Provides fast access to the Target Time training mode.

# USING THE MONITOR

---

## Power On:

1. When powered on, the LCD will fully display for 1 second (as shown in Figure 1) with a long beep sound.
2. The device will then enter display standby mode (as shown in Figure 2), with icons appearing sequentially from top to bottom.



(FIG 1)

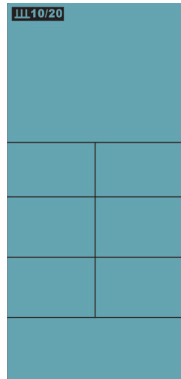

(FIG 2)

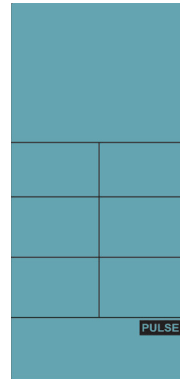
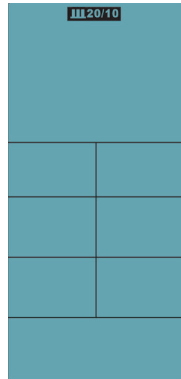

3. To enter standby mode manually, press and hold the STOP button for 2 seconds.

**NOTE:** If there is no input from key operations or RPM signals within 4 minutes, the LCD will automatically switch to Sleep Mode (as shown in Figure 3).

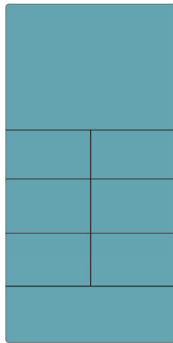

(FIG 3)

### Break Mode:

1. When the workout is in progress, press the "START" button once to enter Break Mode. In this mode, a buzzer will sound for 0.5 seconds every 30 seconds.
2. While in Break Mode, the computer will continue displaying all functions, but the LCD screen will show "P".
3. After 5 minutes in Break Mode, the system will automatically enter Standby Mode, accompanied by a 1-second buzzer sound. To resume your workout, press the "START" button again. (Refer to Figure 4).

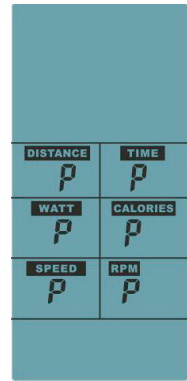

(FIG4)

### Stop Mode:

1. Press the "STOP" button to enter Stop Mode. A buzzer will sound for 0.5 seconds, and all LCD windows will go blank momentarily. After 0.5 seconds, the LCD will display the workout data, including TIME, DISTANCE, and CALORIES (showing values in kilometers or miles, based on the settings).
2. After 7 seconds, accompanied by a buzzer sound of 0.25 seconds, the LCD will display the maximum values for WATTS, SPEED, and PULSE. After another 7 seconds with a 0.25-second buzzer sound, the LCD will display the average values for WATTS, SPEED, and RPM.
3. If no further input is detected, the LCD will show the data twice more before automatically entering Standby Mode. (Refer to Figure 5).



(FIG5)

## Quick Start:

1. While in Standby Mode, if the RPM exceeds 20, press the "START" button. A buzzer will sound for 0.5 seconds, and the LCD will sequentially display TIME, CALORIES, DISTANCE, WATTS, SPEED, and RPM.
2. The displayed values will begin counting up based on the ongoing operation.
3. B. The "PULSE" icon will light up. If a heart rate signal is detected, the "PULSE" icon will flash and display the current value. If no heart rate signal is detected, the LCD will display "P."
4. C. If no input is detected within 5 minutes, the buzzer will sound for 0.5 seconds, and the system will return to Standby Mode.
5. D. If the setting is not completed within 30 seconds, the buzzer will sound for 0.5 seconds, and the system will return to Standby Mode.
6. E. Press the "START" button once to enter Break Mode. Press "START" again to resume operation.
7. F. Press the "STOP" button to trigger a buzzer sound for 0.5 seconds and enter Stop Mode.
8. G. If movement results are being displayed, press the "STOP" button to exit and return to Standby Mode.
9. H. When adjusting the adjustment button, the LOAD resistance level for each segment will be displayed in the WATT window.



(FIG6)

## INTERVAL 10/20:

1. Press the "INTERVAL 10/20" button to enter this mode. The LCD will display the INTERVAL 10/20 icon, accompanied by a buzzer sound lasting 0.5 seconds.
2. If no input is detected within 30 seconds during setup, the computer will return to Standby Mode.
3. The "READY" icon will count down from 3 to 0, accompanied by a short buzzer sound (see FIG 7). The LCD will display "01/XX" (where "01" flashes). The "WORK" icon flashes once every second with buzzer sounds (lasting 0.75 seconds and pausing for 0.25 seconds).
4. The "TIME" icon will count down from 10 to 0, and the DISTANCE, CALORIES, WATTS, SPEED, and RPM values will count up based on the user's activity. (See FIG 8).

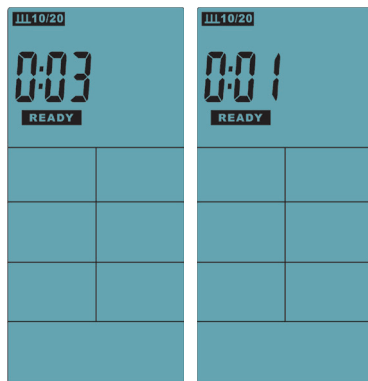

(FIG7)

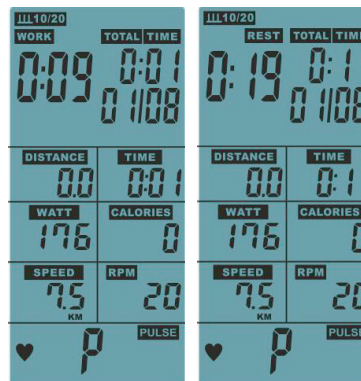

(FIG8)

5. After 10 seconds of work, the LCD will display "01/08" (with "01" flashing). The "REST" icon will begin flashing, and a buzzer will sound for 0.25 seconds every second. The timer will then start counting down from 20 seconds to 0.
6. The "WORK" and "REST" phases will alternate in cycles, with the cycle count increasing by 1 each time until it reaches "08/08" (a total of 8 cycles). A buzzer will sound for 0.5 seconds to indicate the end of the cycle and entry into Stop Mode. (Note: The average value of workout results is calculated only during the "WORK" phase.)
7. When the final "REST" phase is completed, the program will stop automatically.
8. If no input is detected within 5 minutes, a buzzer will sound for 0.5 seconds, and the system will enter Standby Mode.
9. Press the "START" button once to enter Break Mode. Press "START" again to resume operation.
10. Press the "STOP" button to sound a buzzer for 0.5 seconds and enter Stop Mode.
11. If workout results are displayed, press the "STOP" button to exit and return to Standby Mode.

### INTERVAL 20/10:

1. Press the "INTERVAL 20/10" button to enter this mode. The LCD will display the INTERVAL 20/10 icon (see FIG 10), and a buzzer will sound for 0.5 seconds.
2. If no input is detected within 30 seconds during setup, the computer will return to Standby Mode.
3. The "READY" icon will count down from 3 to 0, accompanied by a short buzzer sound (see FIG 7). The LCD will display "01/XX" (with "01" flashing). The "WORK" icon flashes once every second, accompanied by a buzzer (0.75 seconds on, 0.25 seconds off).
4. The "TIME" icon will count down from 10 to 0, while DISTANCE, CALORIES, WATTS, SPEED, and RPM values will increase based on the user's activity (see FIG 10).

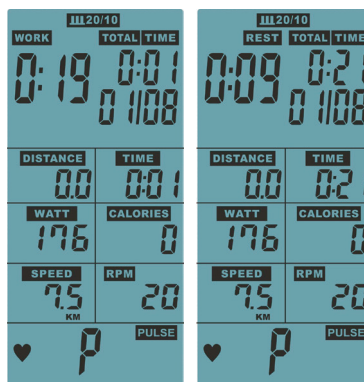

(FIG10)

5. After 10 seconds of work, the LCD will display "01/08" (with "01" flashing). The "REST" icon will start flashing, and a buzzer will sound for 0.25 seconds every second. The timer will then count down from 20 seconds to 0.
6. The "WORK" and "REST" phases alternate in cycles, with the cycle count increasing by 1 each time until it reaches "08/08" (a total of 8 cycles). A buzzer will sound for 0.5 seconds to indicate the end of the program and entry into Stop Mode. (Note: The average workout results are calculated only during the "WORK" phase.)
7. When the final "REST" phase is completed, the program will stop automatically.
8. If no input is detected within 5 minutes, a buzzer will sound for 0.5 seconds, and the system will enter Standby Mode.
9. Press the "START" button once to enter Break Mode. Press "START" again to resume operation.
10. Press the "STOP" button to trigger a buzzer for 0.5 seconds and enter Stop Mode.
11. If workout results are displayed, press the "STOP" button to exit and return to Standby Mode.

## INTERVAL CUSTOM:

1. Press the "INTERVAL CUSTOM" button to enter this mode. The LCD will display the INTERVAL CUSTOM icon (see FIG 13), and a buzzer will sound for 0.5 seconds.
2. The LCD will display the preset value 01. Use the "UP" and "DOWN" buttons to adjust the setting (range: 01–20). This setting is non-recyclable (see FIG 14).
3. After pressing "ENTER," the "WORK" icon will begin flashing, and the LCD will display "TOTAL TIME," showing the preset value of 0:30. Use the "UP" and "DOWN" buttons to adjust the setting (range: 0:05–30:00). This setting is non-recyclable (see FIG 15).
4. Press "ENTER" again, and the "REST" icon will start flashing. The LCD will display "TOTAL TIME," showing the preset value of 0:20. Use the "UP" and "DOWN" buttons to adjust the setting (range: 0:05–30:00). This setting is also non-recyclable (see FIG 16).
5. After confirming with "ENTER," a short buzzer will sound for 0.5 seconds. The LCD will display "01/XX" (with "01" flashing). The "WORK" icon will flash once every second with buzzer sounds (0.75 seconds on, 0.25 seconds off). The "TIME" icon will count down from the set value while DISTANCE, CALORIES, WATTS, SPEED, and RPM increase based on the user's activity.
6. During the REST phase, the matrix will display "01/XX" (with "01" flashing). The "REST" icon will flash, and a buzzer will sound for 0.25 seconds every second.
7. The "WORK" and "REST" phases will alternate in cycles, with the cycle count increasing by 1 each time until it reaches "08/08" (a total of 8 cycles). A buzzer will sound for 0.5 seconds, indicating the end of the program and entry into Stop Mode. (Note: The average workout results are calculated only during the "WORK" phase.)
8. When the final "REST" phase is completed, the program will stop automatically.
9. If no input is detected within 5 minutes, a buzzer will sound for 0.5 seconds, and the system will enter Standby Mode.
10. Press the "START" button once to enter Break Mode. Press "START" again to resume operation.
11. Press the "STOP" button to sound a buzzer for 0.5 seconds and enter Stop Mode.
12. If workout results are displayed, press the "STOP" button to exit and return to Standby Mode.
13. After 10 seconds of work, the LCD will display "01/08" (with "01" flashing). The "REST" icon will start flashing, and a buzzer will sound for 0.25 seconds every second. The timer will then count down from 20 seconds to 0.

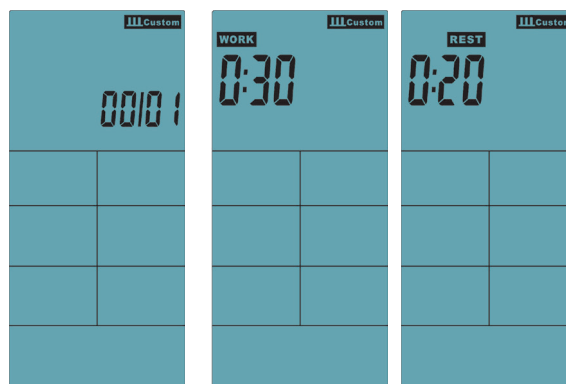

(FIG14)

(FIG15)

(FIG16)

14. The "WORK" and "REST" phases alternate in cycles, with the cycle count increasing by 1 each time until it reaches "08/08" (a total of 8 cycles). A buzzer will sound for 0.5 seconds to indicate the end of the program and entry into Stop Mode. (Note: The average workout results are calculated only during the "WORK" phase.)
15. When the final "REST" phase is completed, the program will stop automatically.
16. If no input is detected within 5 minutes, a buzzer will sound for 0.5 seconds, and the system will enter Standby Mode.
17. Press the "START" button once to enter Break Mode. Press "START" again to resume operation.
18. Press the "STOP" button to trigger a buzzer for 0.5 seconds and enter Stop Mode.
19. If workout results are displayed, press the "STOP" button to exit and return to Standby Mode.

#### TARGET TIME:

1. Press the "TARGET TIME" button to enter this mode. The LCD will flash and display TARGET & TIME.
2. The "TIME" window will display the preset value of 1:00 or the last set value. Use the "UP" and "DOWN" buttons to adjust the setting (range: 1:00–1:59:00). This setting is non-recyclable.
3. After setting, press "ENTER" to confirm. The TARGET & TIME icon will continue flashing, and the countdown will start from the set value.
4. Press the "START" button once to enter Break Mode. Press "START" again to resume operation.
5. Press the "STOP" button to trigger a buzzer for 0.5 seconds and enter Stop Mode.
6. If no input is detected within 5 minutes, a buzzer will sound for 0.5 seconds, and the system will enter Standby Mode.
7. If the setting is not completed within 30 seconds, a buzzer will sound for 0.5 seconds, and the system will return to Standby Mode.
8. If workout results are displayed, press the "STOP" button to exit and return to Standby Mode.



## TARGET CALORIES:

1. Press the "TARGET CALORIE" button to enter this mode. The LCD will flash and display TARGET & CALORIE.
2. The "CALORIE" window will display the preset value of 2:00 or the last set value. Use the "UP" and "DOWN" buttons to adjust the setting (range: 1–2000). This setting is non-recyclable.
3. After setting, press "ENTER" to confirm. The TARGET & CALORIE icon will continue flashing, and the countdown will start from the set value.
4. Press the "START" button once to enter Break Mode. Press "START" again to resume operation.
5. Press the "STOP" button to trigger a buzzer for 0.5 seconds and enter Stop Mode.
6. If no input is detected within 5 minutes, a buzzer will sound for 0.5 seconds, and the system will enter Standby Mode.
7. If the setting is not completed within 30 seconds, a buzzer will sound for 0.5 seconds, and the system will return to Standby Mode.
8. If workout results are displayed, press the "STOP" button to exit and return to Standby Mode.

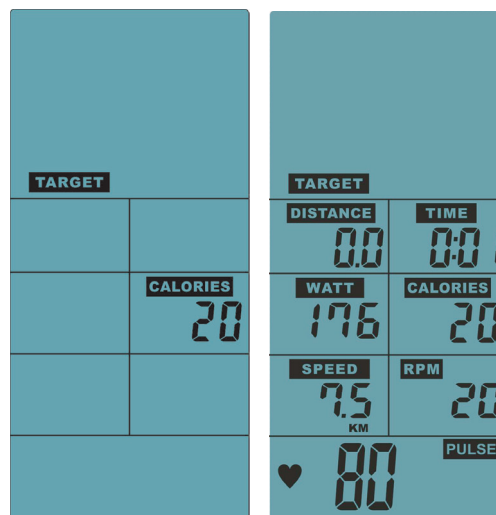

## TARGET DISTANCE:

1. Press the "TARGET DISTANCE" button to enter this mode. The LCD will flash and display TARGET & DISTANCE.
2. The "DISTANCE" window will display the preset value of 0.5 KM/0.5 Miles or the last set value. Use the "UP" and "DOWN" buttons to adjust the setting (range: 0.5–100.0). This setting is non-recyclable.
3. After setting, press "ENTER" to confirm. The TARGET & DISTANCE icon will continue flashing, and the countdown will start from the set value.
4. Press the "START" button once to enter Break Mode. Press "START" again to resume operation.
5. Press the "STOP" button to trigger a buzzer for 0.5 seconds and enter Stop Mode.
6. If no input is detected within 5 minutes, a buzzer will sound for 0.5 seconds, and the system will enter Standby Mode.
7. If the setting is not completed within 30 seconds, a buzzer will sound for 0.5 seconds, and the system will return to Standby Mode.
8. If workout results are displayed, press the "STOP" button to exit and return to Standby Mode.

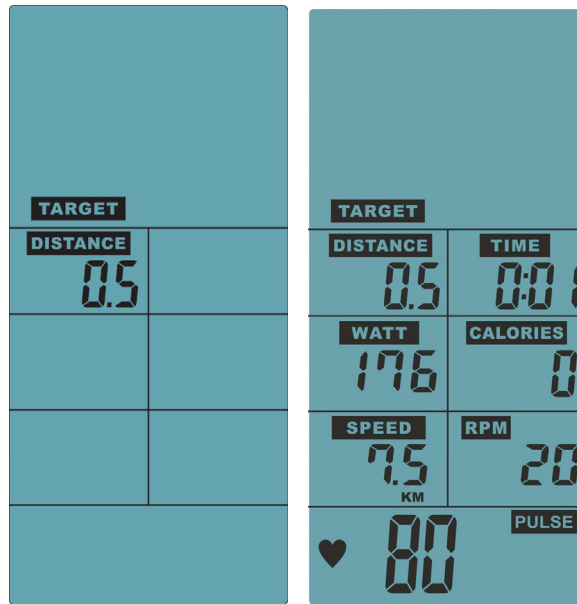

**TARGET HEART RATE:**

1. Press the "TARGET HEART RATE" button to enter this mode. The LCD will flash and display the Age Icon, with a preset value of 30 or the last set value. Use the "UP" and "DOWN" buttons to adjust the setting (range: 11-120). This setting is non-recyclable.
2. After setting, press "ENTER" to confirm. The LCD will display a preset value of 65%. Use the "UP" and "DOWN" buttons to adjust to either 65% or 85%, and the LCD will display the corresponding pulse value.
3. If the PULSE option is selected, the LCD will display a preset value of 100. Use the "UP" and "DOWN" buttons to adjust the setting (range: 30-230). This setting is non-recyclable.
4. Press the "ENTER" button to start counting. The TARGET & PULSE icons will begin flashing.
5. When the heartbeat value is higher or lower than the set value ( $\pm 10\%$ ), the pulse value will be displayed continuously.
6. If the heartbeat value is lower than the set value by more than 10%, the PULSE window will flash the "UP ICON" to remind the user to accelerate.
7. If the heartbeat value is higher than the set value by more than 10%, the PULSE window will flash the "DOWN ICON" to remind the user to slow down.
8. If the heartbeat value exceeds or equals 100% of the set value, the buzzer will sound three short tones every 1 second. After 10 repetitions, if the heartbeat value does not drop below 100%, the buzzer will ring for 1 second continuously, and the system will enter Standby Mode.

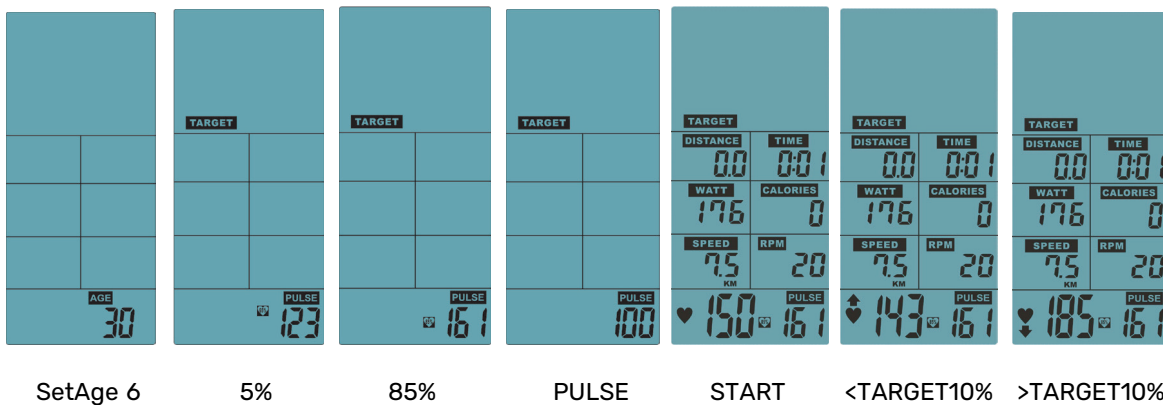

9. If there is no heart rate input within 30 seconds, the PULSE LCD will display "P," and the buzzer will sound for 1 second before entering Standby Mode.
  10. Press the "START" button once to enter Break Mode. Press "START" again to resume operation.
  11. Press the "STOP" button to trigger a buzzer for 0.5 seconds and enter Stop Mode.
  12. If no input is detected within 5 minutes, a buzzer will sound for 0.5 seconds, and the system will enter Standby Mode.
  13. If the setting is not completed within 30 seconds, the buzzer will sound for 0.5 seconds, and the system will return to Standby Mode.
  14. If workout results are displayed, press the "STOP" button to exit and return to Standby Mode.
- 

**Quality Assurance Statement:**

This equipment has been manufactured at a facility certified for quality management under the ISO 9001:2015 standard. The certification ensures that the processes used in the design and production of this equipment meet international standards for quality and reliability.

The scope of the certification includes the designing and production of fitness equipment and accessories, ensuring a commitment to quality throughout the production process. This certification was valid at the time your equipment was produced.

# YOU'RE FINISHED!

WANT TO LEARN MORE ABOUT THE BLITZ MAX AIR BIKE?  
CHECK OUT THE OVERVIEW VIDEO:



## VISIT OUR SHOWROOMS



Calgary - HQ



Toronto - Showroom



Indianapolis - Showroom

Corporate Headquarters 7880 66 St SE, Calgary, AB, Canada

U.S.A. Headquarters 5925 W 71st St, Indianapolis, IN, U.S.A.

Toronto Store 39 Haist Ave # 2, Woodbridge, ON, Canada

[support@bellssofsteel.com](mailto:support@bellssofsteel.com) | 1-888-718-7997